

OPERATION MANUAL

MARINE ENGINE

6LY

6LY440

6LY400

 English

YANMAR

California Proposition 65 Warning

Diesel engine exhaust and some of its constituents are known to the state of California to cause cancer, birth defects, and other reproductive harm.

Disclaimers:

All information, illustrations and specifications in this manual are based on the latest information available at the time of publishing. The illustrations used in this manual are intended as representative reference views only. Moreover, because of our continuous product improvement policy, we may modify information, illustrations and/or specifications to explain and/or exemplify a product, service or maintenance improvement. We reserve the right to make any change at any time without notice. Yanmar and **YANMAR** are registered trademarks of YANMAR CO., LTD. in Japan, the United States and/or other countries.

All Rights Reserved:

No part of this publication may be reproduced or used in any form by any means - graphic, electronic, or mechanical, including photocopying, recording, taping, or information storage and retrieval systems - without the written permission of YANMAR CO., LTD.

Please review and comply with the applicable laws and regulations of the international export control regimes at the territory or country where the product and manual are intended to be imported and used.

OPERATION MANUAL	MODEL	6LY440, 6LY400
	CODE	0ALYC-EN0013

TABLE OF CONTENTS

	Page
INTRODUCTION	1
RECORD OF OWNERSHIP	2
SAFETY	3
SAFETY PRECAUTIONS	4
General Information	4
Before You Operate	4
During Operation and Maintenance	4
LOCATION OF SAFETY DECALS	8
PRODUCT OVERVIEW	11
YANMAR 6LY COMMON RAIL SERIES FEATURES AND APPLICATIONS	11
New Engine Break-In	12
COMPONENT IDENTIFICATION	13
Right Side (Viewed from Flywheel)	13
Left Side (Viewed from Flywheel)	13
NAMEPLATES	14
FUNCTION OF MAJOR COMPONENTS	15
ELECTRONIC CONTROL SYSTEM	16
MAIN ELECTRONIC CONTROL COMPONENTS AND FEATURES	17
VESSEL CONTROL SYSTEM (VC10)	18
Display	19
BEFORE YOU OPERATE	23
INTRODUCTION	23
SAFETY PRECAUTIONS	23

TABLE OF CONTENTS

DIESEL FUEL.....	24
Diesel Fuel Specifications	24
Filling the Fuel Tank.....	27
Bleeding the Fuel System	28
ENGINE OIL	29
Engine Oil Specifications	29
Engine Oil Viscosity	29
Checking the Engine Oil.....	30
Adding Engine Oil	30
MARINE GEAR OIL.....	31
Marine Gear Oil Specifications.....	31
Checking Marine Gear Oil.....	31
Adding Marine Gear Oil.....	31
ENGINE COOLANT	32
Engine Coolant Specifications	32
Coolant (Closed Cooling System)	32
Checking and Adding Coolant.....	33
ENGINE OPERATION	37
INTRODUCTION	37
SAFETY PRECAUTIONS.....	37
OPERATION	
(VC10: VESSEL CONTROL SYSTEM).....	39
Starting the Engine.....	39
Station Protect.....	41
Sys on by ID, Start by ID	41
Owner ID Change	41
If the Engine Fails to Start.....	42
Starting at Low Temperatures.....	42
After the Engine has Started	42
WARM UP MODE (SHIFT DISCONNECT).....	43
THROTTLE AND SHIFT CONTROL	44
Neutral.....	44
Forward	44
Reverse	44
Forward (Reverse) to Reverse (Forward)	44
ENGINE SPEED LIMIT MODE.....	45
CAUTIONS DURING OPERATION.....	45
SHUT-DOWN THE ENGINE (STOPPING)	47
Normal Stopping	47
Emergency Stop.....	48
CONTROL THE BACKUP PANEL	49
CHECKING THE ENGINE AFTER OPERATION.....	50

PERIODIC MAINTENANCE	51
INTRODUCTION.....	51
SAFETY PRECAUTIONS	51
PRECAUTIONS	53
The Importance of Periodic Maintenance	53
Performing Periodic Maintenance	53
The Importance of Daily Checks	53
Keep a Log of Engine Hours and Daily Checks ..	53
Yanmar Replacement Parts	53
Tools Required	53
Consult Your Authorized Yanmar Marine Dealer or Distributor for Help	53
Tightening Fasteners.....	54
EPA MAINTENANCE REQUIREMENTS	55
EPA Requirements for USA and Other Applicable Countries.....	55
Environmental Condition for operation and maintenance	56
Inspection and Maintenance.....	57
Installation of Exhaust Sampling Port.....	57
PERIODIC MAINTENANCE SCHEDULE	58
Inspection and Maintenance of EPA Emission-Related Parts	61
PERIODIC MAINTENANCE PROCEDURES	62
Daily Checks.....	62
After Initial 50 Hours of Operation	63
Every 50 Hours of Operation	65
After Initial 250 Hours of Operation	67
Every 250 Hours of Operation	67
Every 1 Year of Operation	72
Every 1000 Hours of Operation	74
Every 2000 Hours of Operation	75
Every 2 Years of Operation	75
TROUBLESHOOTING	77
SAFETY PRECAUTIONS	77
TROUBLESHOOTING AFTER STARTING	77
TROUBLESHOOTING INFORMATION.....	78
TROUBLESHOOTING CHART.....	79
FAILSAFE DIAGNOSIS FUNCTIONAL SPECIFICATION CHART	84

TABLE OF CONTENTS

LONG-TERM STORAGE	91
PREPARE ENGINE FOR LONG-TERM STORAGE	91
DRAIN SEAWATER COOLING SYSTEM.....	92
RETURNING THE ENGINE TO SERVICE	93
SPECIFICATIONS	95
PRINCIPAL ENGINE SPECIFICATIONS.....	95
6LY440/6LY400 Engine	96
Marine Gear Specifications	97
SYSTEM DIAGRAMS	99
PIPING DIAGRAMS	99
WIRING DIAGRAMS	105
EPA WARRANTY USA ONLY	109
YANMAR CO., LTD. LIMITED EMISSION CONTROL SYSTEM WARRANTY - USA ONLY ...	109
Your Warranty Rights and Obligations:.....	110
Warranty Period:	110
Warranty Coverage:.....	111
Exclusions:	111
Owner's Responsibility:.....	111
Customer Assistance:	111
Maintenance Log.....	112

INTRODUCTION

Welcome to the world of Yanmar Marine! Yanmar Marine offers engines, drive systems and accessories for all types of boats, from runabouts to sailboats, and from cruisers to mega yachts. In marine leisure boating, the worldwide reputation of Yanmar Marine is second to none. We design our engines to respect nature. This means quieter engines, with minimal vibrations, cleaner than ever. All of our engines meet applicable regulations, including emissions, at the time of manufacture.

To help you enjoy your Yanmar 6LY common rail series engine for many years to come, please follow these recommendations:

- Read and understand this *Operation Manual* before you operate the machine to ensure that you follow safe operating practices and maintenance procedures.
- Keep this *Operation Manual* in a convenient place for easy access.
- If this *Operation Manual* is lost or damaged, order a new one from your authorized Yanmar Marine dealer or distributor.
- Make sure this manual is transferred to subsequent owners. This manual should be considered a permanent part of the engine and remain with it.
- Constant efforts are made to improve the quality and performance of Yanmar products, so some details included in this *Operation Manual* may differ slightly from your engine. If you have any questions about these differences, please consult your authorized Yanmar Marine dealer or distributor.
- The specifications and components (instrument panel, fuel tank, etc.) described in this manual may differ from ones installed on your vessel. Please refer to the manual provided by the manufacturer of these components.
- Refer to the Yanmar Limited Warranty Handbook for a complete warranty description.

INTRODUCTION

RECORD OF OWNERSHIP

Take a few moments to record the information you need when you consult Yanmar for service, parts or documentation.

Engine Model: _____

Engine Serial No.: _____

Date Purchased: _____

Dealer: _____

Dealer Phone: _____

SAFETY

Yanmar considers safety of great importance and recommends that anyone that comes into close contact with its products, such as those who install, operate, maintain or service Yanmar products, exercise care, common sense and comply with the safety information in this manual and on the machine's safety decals. Keep the labels from becoming dirty or torn and replace them if they are lost or damaged. Also, if you need to replace a part that has a label attached to it, make sure you order the new part and label at the same time.



This safety alert symbol appears with most safety statements. It means attention, become alert, your safety is involved! Please read and abide by the message that follows the safety alert symbol.

DANGER

Indicates a hazardous situation which, if not avoided, *will* result in death or serious injury.

WARNING

Indicates a hazardous situation which, if not avoided, *could* result in death or serious injury.

CAUTION

Indicates a hazardous situation which, if not avoided, *could* result in minor or moderate injury.

NOTICE

Indicates a situation which can cause damage to the machine, personal property and/or the environment, or cause the equipment to operate improperly.

SAFETY PRECAUTIONS

General Information

There is no substitute for common sense and careful practices. Improper practices or carelessness can cause burns, cuts, mutilation, asphyxiation, other bodily injury or death. This information contains general safety precautions and guidelines that must be followed to reduce risk to personal safety. Special safety precautions are listed in specific procedures. Read and understand all of the safety precautions before operation or performing repairs or maintenance.

Before You Operate

DANGER

The safety messages that follow have DANGER level hazards.



Never permit anyone to install or operate the engine without proper training.

Read and understand this *Operation Manual* before you operate or service the engine to ensure that you follow safe operating practices and maintenance procedures.

- Safety signs and labels are additional reminders for safe operating and maintenance techniques.
- Consult authorized Yanmar Marine dealer or distributor for additional training.

During Operation and Maintenance

WARNING

The safety messages that follow have WARNING level hazards.

Explosion Hazard



While the engine is running or the battery is charging, hydrogen gas is being produced and can be easily ignited. Keep the area around the battery

well-ventilated and keep sparks, open flames and any other form of ignition out of the area.

Fire and Explosion Hazard

Diesel fuel is flammable and explosive under certain conditions.

Never use a shop rag to catch the fuel.

Wipe up all spills immediately.

Never refuel with the engine running.

Fire Hazard



Undersized wiring systems can cause an electrical fire. Never use improper capacity of fuses.

Store any containers containing fuel or other flammable products in a well-ventilated area, away from any combustibles or source of ignition.

Store any equipment in a designated area away from moving parts.

Never use the engine compartment for storage.

⚠ WARNING**Sever Hazard**

Rotating parts can cause severe injury or death. Never wear jewelry, unbuttoned cuffs, ties or loose-fitting clothing and always tie long hair back when working near moving/rotating parts such as the flywheel or PTO shaft. Keep hands, feet and tools away from all moving parts.

Alcohol and Drug Hazard

Never operate the engine while under the influence of alcohol or drugs, or when feeling ill.

Exposure Hazard

Always wear personal protective equipment including appropriate clothing, gloves, work shoes, and eye and hearing protection as required by the task at hand.

Sudden Movement Hazard

Never operate the engine while wearing a headset to listen to music or radio because it will be difficult to hear the warning signals.

Burn Hazard

Some of the engine surfaces become very hot during operation and shortly after shutdown. Keep hands and other body parts away from hot engine surfaces.

Exhaust Hazard

Never block windows, vents or other means of ventilation if the engine is operating in an enclosed area. All internal combustion engines create carbon monoxide gas during operation and special precautions are required to avoid carbon monoxide poisoning.

CAUTION

The safety messages that follow have CAUTION level hazards.

Poor Lighting Hazard

Ensure that the work area is adequately illuminated. Always install wire cages on portable safety lamps.

Tool Hazard

Always use tools appropriate for the task at hand and use the correct size tool for loosening or tightening machine parts.

Flying Object Hazard

Always wear eye protection when servicing the engine or when using compressed air or high-pressure water. Dust, flying debris, compressed air, pressurized water or steam may injure your eyes.

Coolant Hazard



Wear eye protection and rubber gloves when you handle engine coolant. If contact with the eyes or skin should occur, flush eyes and wash immediately with clean water.

NOTICE

The safety messages that follow have NOTICE level hazards.

It is important to perform daily checks as listed in the *Operation Manual*. Periodic maintenance prevents unexpected downtime, reduces the number of accidents due to poor engine performance and helps extend the life of the engine.

Consult authorized Yanmar Marine dealer or distributor if you need to operate the engine at high altitudes. At high altitudes the engine will lose power, run rough and produce exhaust gases that exceed the design specifications.



Always be environmentally responsible.

Follow the guidelines of the EPA or other governmental agencies for the proper disposal of hazardous materials such as engine oil, diesel fuel and engine coolant. Consult the local authorities or reclamation facility.

Never dispose of hazardous materials by dumping them into a sewer, on the ground, or into ground water or waterways.

If a Yanmar Marine Engine is installed at an angle that exceeds the specifications stated in the Yanmar Marine *Installation Manuals*, engine oil may enter the combustion chamber causing excessive engine speed, white exhaust smoke and serious engine damage. This applies to engines that run continuously or those that run for short periods of time.

NOTICE

If you have an installation with two or three engines and only one engine is operating, the water pickup (thru-hull) of the non-running engine(s) should be closed. This will prevent water from being forced past the seawater pump and eventually finding its way into the engine. The result of water entering the engine could cause seizure or other serious problems.

If you have an installation with two or three engines, and only one engine is operating, please note that if the propeller shaft thru-hull (stuffing box) is lubricated by engine water pressure and the engines are interconnected, care must be taken that water from the running engine does not enter the exhaust of the non-running engine(s). This water could cause seizure of the non-running engine(s). Consult authorized Yanmar Marine dealer or distributor for a complete explanation of this condition.

If you have an installation with two or three engines, and only one engine is operating, it is important to limit the amount of throttle applied to the running engine. If you observe black smoke or movement of the throttle does not increase engine speed, you are overloading the engine that is running. Immediately throttle back to approximately 2/3 throttle or to a setting where the engine performs normally. Failure to do so may cause the running engine to overheat or cause excess carbon buildup which may shorten the engine's life.

Never turn off the battery switch (if equipped) or short the battery cables during operation. Damage to the electrical system will result.

LOCATION OF SAFETY DECALS

Figure 1 and Figure 2 show the location of safety decals on Yanmar 6LY common rail series marine engine.

6LY440, 6LY400 Engine

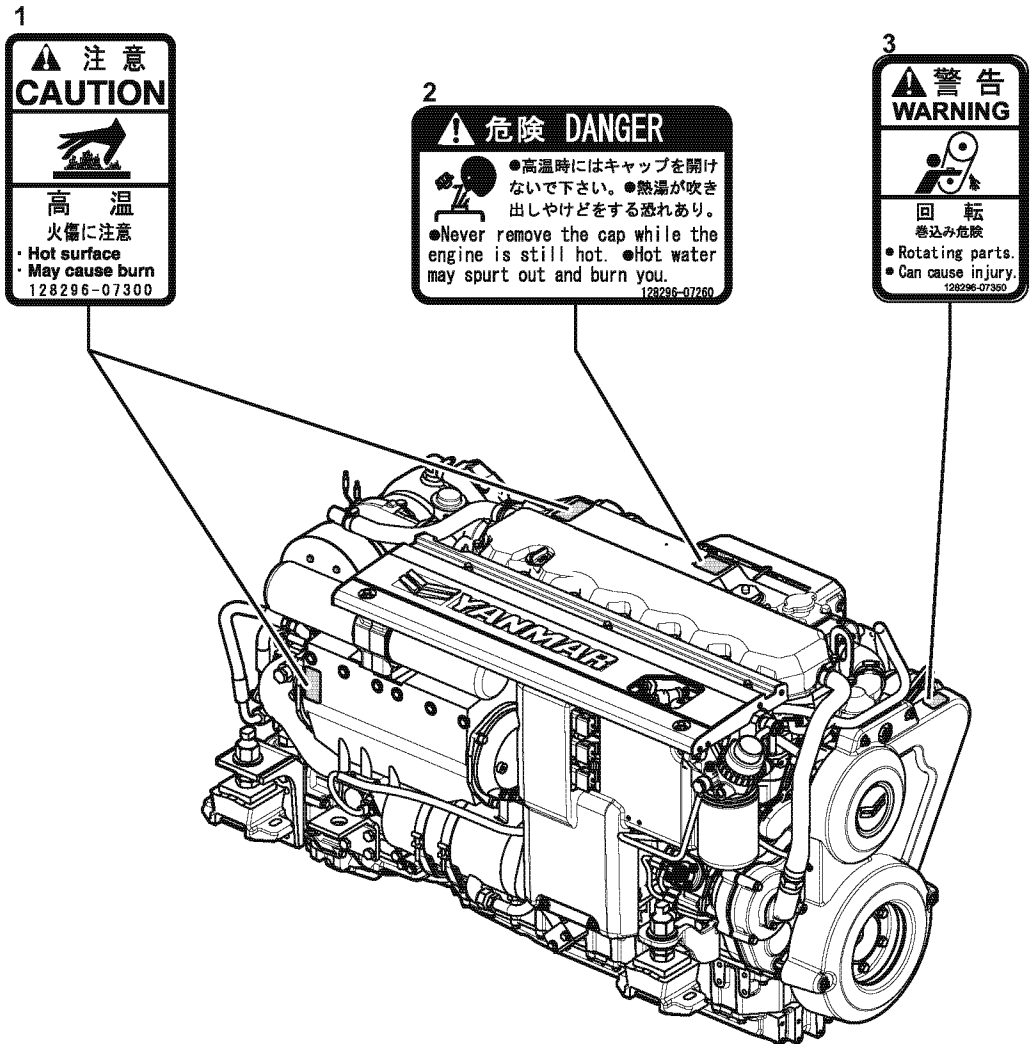

070149-00X00

Figure 1

1-Part Number: 128296-07300

2-Part Number: 128296-07260

3-Part Number: 128296-07350

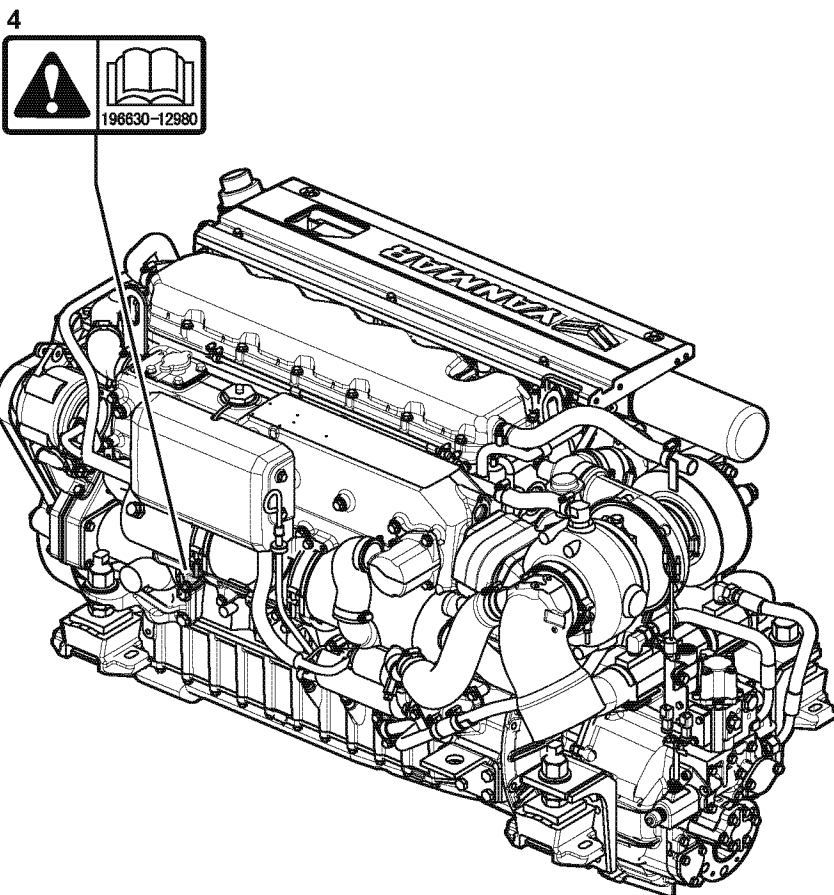

Figure 2

4-Part Number: 196630-12980

This Page Intentionally Left Blank

PRODUCT OVERVIEW

YANMAR 6LY COMMON RAIL SERIES FEATURES AND APPLICATIONS

The 6LY common rail series are four-stroke diesel engines equipped with direct injection common rail system and with liquid coolant systems.

The 6LY440 and 6LY400 are 6-cylinder and turbocharged with an air cooler.

The engines are equipped with a marine gear. (Option)

These engines are designed for recreational craft use.

It is recommended that new vessels be propped so the engines can operate at 50 to 100 min⁻¹ above the fuel stop power engine speed to allow for some added weight and hull resistance.

Failure to do so can lead to reduced vessel performance, lead to increased smoke levels and cause permanent damage to your engine.

The engine must be installed correctly with coolant lines, exhaust gas lines and electrical wiring. Any auxiliary equipment attached to the engine should be easy to use and accessible for service. To handle the drive equipment, propulsion systems (including the propeller) and other inboard equipment, always observe the instructions and cautions given in the operation manuals supplied by the shipyard and equipment manufacturers.

The 6LY common rail series engines are designed to be operated at maximum throttle*¹ for less than 5% of total engine time (30 minutes out of every 10 hours) and cruising speed*².

The laws of some countries may require hull and engine inspections, depending on the use, size and cruising area of the boat. The installation, fitting and surveying of this engine all require specialized knowledge and engineering skills. See Yanmars local subsidiary in your region or your authorized Yanmar Marine dealer or distributor.

*¹ maximum throttle: fuel stop power engine speed

*² cruising speed: fuel stop power engine speed -200 min⁻¹ or less

PRODUCT OVERVIEW

New Engine Break-In

As with all reciprocating engines, the way your engine is operated during its first 50 hours of operation plays a very significant role in determining how long it will last and how well the engine will perform over its lifetime.

A new Yanmar diesel engine must be operated at suitable speeds and power settings during the break-in period to make the sliding parts, such as piston rings, break-in properly and to stabilize engine combustion.

During the break-in period, the engine coolant temperature gauge should be monitored; temperature should be between 71° and 87°C (160° and 190°F).

During the first 10 hours of operation, the engine should be run at maximum engine speed minus 400 to 500 min⁻¹ (approximately 60 to 70% of load) most of the time. This will ensure the sliding parts break in properly. During this period, avoid operating at maximum engine speed and load to avoid damaging or scoring sliding parts.

NOTICE

Do not operate at WOT (wide open throttle) for more than a minute at a time during the first 10 hours of operation.

Do not operate the engine at low idle or at low speed and light load for more than 30 minutes at a time. Since unburned fuel and engine oil will adhere to the piston rings when operating at low speeds for long periods, this will interfere with proper movement of the rings and the engine oil consumption may increase. Low idle speed does not allow break-in of sliding parts.

If operating engine at low speed and light load, you must race the engine to clean the carbon from the cylinders and fuel injection valve.

Perform this procedure in open waters:

- With the clutch in NEUTRAL, accelerate from the low-speed position to the high-speed position briefly.
- Repeat this process five times.

Once past the initial 10 hours until 50 hours, the engine should be used over its full operating range, with special emphasis on running at relatively high power settings. This is not the time for an extended cruise at idle or low speed. The boat should be run at maximum speed minus 400 min⁻¹ most of the time (approximately 70% load), with a 10 minute run at maximum minus 200 min⁻¹ (approximately 80% load) every 30 minutes and a 4 to 5 minute period of operation at WOT (wide open throttle) once each 30 minutes. During this period, be sure not to operate your engine at low speed and light load for more than 30 minutes. If operating engine at low speed and light load by necessity, just after the low idle operation, be sure to race the engine.

To complete engine break-in, perform *After Initial 50 Hours of Operation* maintenance procedures. *After Initial 50 Hours of Operation* on page 63.

COMPONENT IDENTIFICATION

Figure 1 and **Figure 2** illustrate a typical version of 6LY440/6LY400 engine. Your engine may have different equipment from that illustrated.

Right Side (Viewed from Flywheel)

Left Side (Viewed from Flywheel)

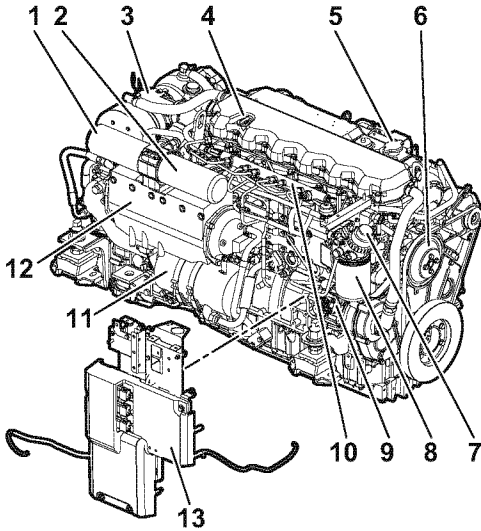

070151-00X00

Figure 1

- 1 – Engine oil filters (Full Flow)
- 2 – Engine oil filter (Bypass)
- 3 – Turbocharger
- 4 – Engine oil filler cap
- 5 – Coolant filler cap
- 6 – Coolant pump
- 7 – Fuel Priming Pump
- 8 – Fuel filter
- 9 – Fuel supply pump
- 10 – Common Rail
- 11 – Engine oil cooler
- 12 – Air cooler
- 13 – ECU

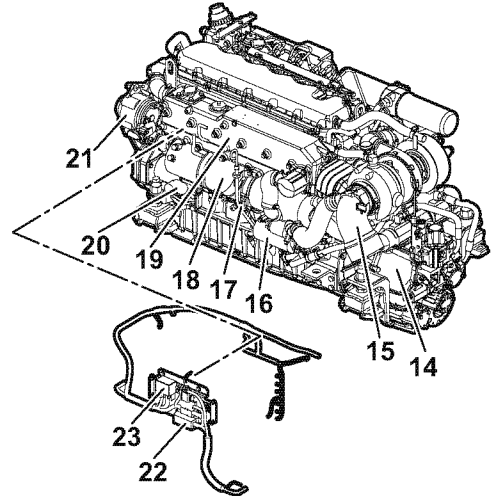

070152-00X00

Figure 2

- 14 – Marine gear
- 15 – Exhaust/water mixing elbow
- 16 – Starter motor
- 17 – Engine oil dipstick
- 18 – Heat exchanger
- 19 – Exhaust manifold (Coolant tank)
- 20 – Seawater pump
- 21 – Alternator
- 22 – Fuse
- 23 – Relay

PRODUCT OVERVIEW

NAMEPLATES

The nameplates of Yanmar 6LY common rail series engines are shown in **Figure 3**. Check the engine's model, output, min⁻¹ and serial number on the nameplate. Please replace if damaged or lost.

The engine nameplate is attached to the top surface of the engine exhaust manifold.

Model	_____
Gear Model	_____
Continuous power kW	_____ kW/ _____ min ⁻¹
Speed of prop.shaft	_____ min ⁻¹ _____
Fuel stop power kW	_____ / _____ min ⁻¹
ENG.No.	_____
MFG.DATE	_____ / _____
YANMAR YANMAR CO.,LTD. MADE IN JAPAN	

129670-07201

Figure 3

The marine gear nameplate (**Figure 4**) is attached to the marine gear. Check the marine gears model, gear ratio, oil used and serial number.

MODEL	_____
MFG. NO.	_____
GEAR RATIO	_____
OIL	_____
YANMAR KANZAKI KOKYUKOKI MFG CO., LTD. MADE IN JAPAN	

177524-02903

Figure 4

FUNCTION OF MAJOR COMPONENTS

Name of Component	Function
Fuel Filter	The fuel filter removes contaminants and sediments from the diesel fuel. Periodic replacement of the fuel filter is necessary. <i>See Periodic Maintenance Schedule on page 58</i> for the replacement frequency.
Fuel pre-filter (Water separator)	The water separator removes contaminants, sediment and water from diesel fuel going to the fuel filter. This is a required component of the fuel system and is standard equipment with every engine. The water separator is installed between the fuel tank and the fuel filter. Periodically drain the water from the water separator using the drain cock at the bottom of the separator and replace the filter element.
Fuel Priming Pump	This is a manual fuel pump. Pushing the knob on the top of the fuel pre-filter feeds the fuel. This pump is also used to bleed air from the fuel system.
Engine Oil Filler Port	Filler port for engine oil.
Engine Oil Filter	Filters fine metal fragments and carbon from the engine oil. Filtered engine oil is distributed to the engine's moving parts. The filter is a cartridge type and the element should be replaced periodically. <i>See Changing the Engine Oil and Replacing the Engine Oil Filter Element on page 64.</i>
Marine Gear Filler Port (Marine Gear is option)	Filler port for marine gear lube oil. Located on top of the marine gear case.
Cooling System	There are two cooling systems: closed cooling with coolant and seawater. The engine is cooled by the closed cooling circuit. The closed circuit is cooled by seawater using a heat exchanger. The seawater also cools the engine/marine gear oil and intake air through the cooler(s) in an open circuit.
Coolant pump	The centrifugal water pump circulates coolant inside the engine. The circulating pump is driven by a V-belt.
Seawater Pump	Pumps seawater from outside vessel to the engine. The seawater pump is gear-driven and has a replaceable rubber impeller. Do not operate it without seawater, as this will damage the impeller.
Reservoir	The pressure valve in the filler cap releases vapor and hot water overflow to the reservoir. When the engine stops and the coolant cools, the pressure in coolant tank drops. The filler cap vacuum valve then opens to send water back from the reservoir. This minimizes coolant consumption. The closed cooling system coolant level can easily be checked and refilled in this tank.
Oil Cooler - Engine	A heat exchanger that cools high temperature engine oil using seawater.
Oil Cooler - Marine Gear (Marine Gear is option)	This heat exchanger cools the marine gear (KMH61A/KMH61V) oil using seawater.
Turbocharger	The turbocharger pressurizes the air coming into the engine. It is driven by a turbine that is energized by exhaust gases.
Air cooler	This heat exchanger cools the pressurized charging air from the turbocharger with seawater to increase the charging air quantity.
Intake Silencer (Air Cleaner)	The intake silencer guards against dirt in the air and reduces the noise of air intake.
Zinc Anode	The metal area of the seawater cooling system is prone to galvanic corrosion. The zinc anode is installed in the various coolers to prevent this. When the zinc anode becomes worn, components in the fresh water cooler, oil cooler, etc. will corrode. Periodic replacement of the zinc anode is necessary.
Nameplates	Nameplates are provided on the engine and the marine gear and have the model, serial number and other data.
Starter	Starter motor for the engine. Powered by the battery.
Alternator	Driven by belt and generates electricity and charges the battery.
Engine Oil Dipstick	Gauge stick for checking the engine oil level.

ELECTRONIC CONTROL SYSTEM

WARNING

- The 6LYcommon rail series engines use a high pressure common rail system.
 - The fuel is injected at extremely high pressure.
 - Never disassemble the fuel system parts.
 - Failure to comply may result in death or serious injury.
 - If a malfunction occurs, consult your nearest Yanmar dealer or distributor.
-
- Never use the ECU for other purposes than intended or in other ways than specified by Yanmar. Doing so could result in the violation of emission control regulations and will void the product warranty.
 - Be sure to use the ECU in conjunction with the engines whose models or serial numbers are specified by Yanmar. Other ECU/engine combinations than specified will void the engine warranty.
 - Replacing the fuel injector involves rewriting the fuel injection data in the ECU. Be sure to consult your local Yanmar dealer before replacing the fuel injector. Failure to rewrite the fuel injection data before replacing the fuel injector will void the engine warranty.
 - Improper use or misuse of the ECU may result in death or serious injury due to an abrupt and unexpected increase in engine speed.

- Replacing the ECU involves migrating the fuel injection data to the existing ECU to the new unit. Be sure to consult your local Yanmar dealer before replacing the ECU. Failure to migrate the fuel injection data before replacing the ECU will void the engine warranty.

NOTICE

- Do not plug or unplug the ECU for a period of at least 6 seconds after power to the unit has been turned on or off.
 - Do not touch connector pins of the ECU with bare hands. Doing so may result in corrosion of the connector pins and/or damage to the internal circuits of the ECU due to static electricity.
 - Do not force a measuring probe into the female coupler. Doing so may cause contact failure of the connector pins, resulting in malfunction of the ECU.
 - Take care to prevent water from entering the couplers when plugging or unplugging the connector. Water inside the couplers may cause corrosion, resulting in malfunction of the ECU.
 - Avoid plugging/unplugging the connector more than approx. 10 times. Frequent plugging/unplugging of the connector may cause contact failure of the connector pins, resulting in malfunction of the ECU.
 - Do not use the ECU that has ever suffered drop impact.
-
- Always check the battery for proper charge. Otherwise the electronically controlled engines may fail to start.
-

MAIN ELECTRONIC CONTROL COMPONENTS AND FEATURES

Component/feature	Description
Controller	By controlling the fuel injection timing, volume, pressure and number in accordance with the target speed indication entered from the accelerator sensor, the controller adjusts the engine speed and power.
Fuel pump (supply pump)	The fuel pump supplies fuel to the common rail.
Common rail	The common rail stores the compressed high-pressure fuel from the supply pump and distributes fuel to the injector in each cylinder.
Fuel injector	The Fuel Injectors the high-pressure fuel from the rail to the engine combustion chamber after receiving a signal from the ECU in the most appropriate injection timing, injection volume, injection ratio, number of injection and spray condition.
Accelerator sensor	Unlike mechanical governors, the common rail fuel injection system has no governor lever. The accelerator sensor serves as the governor lever to provide the speed command signal (voltage signal) to the ECU for engine speed control.
Engine diagnosis tool	Allows the operator to troubleshoot the cause of a problem based on detailed information regarding the problem occurring in the ECU. This tool can also be used for data maintenance tasks including programming and mapping. <i>See Troubleshooting on page 77</i>

VESSEL CONTROL SYSTEM (VC10)

6LY common rail series engine is a fully electronic control engine, which is controlled by Yanmar’s original “Vessel Control System (VC10)”.

The control equipment consists of the Switch Panel, the Display, the Drive & Helm ECU, the Control Head and the Backup Panel, which are connected by the cable harness to the engine and marine gear or Shift Actuator for remote control operation.

Note: The Yanmar Vessel Control System (VC10) was designed to operate the 6LY common rail series and drive system. There are many control functions and diagnostic functions that are integrated together to insure safe operation. If this system is not utilized in specific accordance with the instructions in this manual or the system is modified in any way, Yanmar will not be responsible for any warranty failures in the operation of the system or the vessel utilizing the system. Yanmar has designed the Vessel Control System (VC10) in conjunction with the 6LY common rail series. The system has many functions that must be configured and calibrations must be made before the vessel can be operated. Please arrange to have a Yanmar trained technician inspect the vessel prior to the vessels operation.

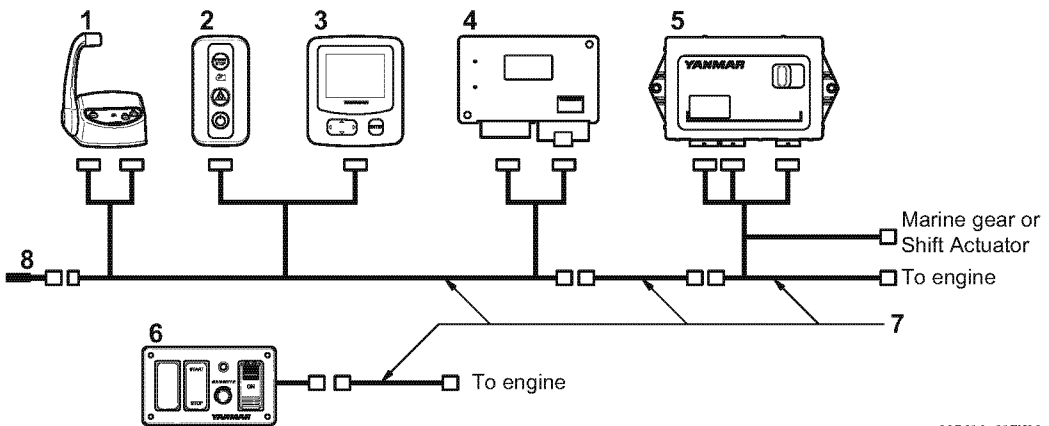

037618-01ENG00

Figure 5

No.	Description
1	Shift and Throttle Control Head
2	Switch Panel (to start and stop the engine)
3	VC10 Digital Display
4	Helm ECU
5	Drive ECU
6	Backup Panel
7	Cable Harness Set
8	Adapter, Terminal

Display

The multi-function information display has the following functions.

Display Function

Runtime Engine Data Tri-Screen

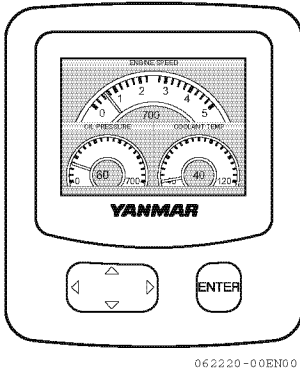

Figure 6

This screen displays real time engine data and alarm indications.

Alarm Indicators

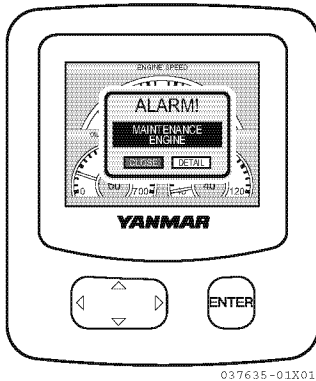

Figure 7

The alarm window appears with an audible alarm when abnormal engine activity occurs.

Note: When starting the engine, make it a rule to check that when the switch panel is pressed to the power switch, the welcome screen appears on the display and goes out. If the system does not function normally, consult your authorized Yanmar Marine dealer or distributor and ask for diagnostics.

Diag Codes Screen

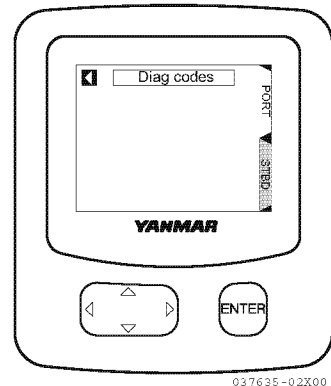

Figure 8

Alarm Indicator Functions

The alarm indicators and buzzer are activated when sensors detect an abnormality during engine operation. The alarm indicators are off during normal operation, but are activated as follows when an abnormality arises:

- The coolant temperature alarm indicator activates when the coolant gets too hot.
- The engine oil pressure alarm indicator activates when the engine oil pressure drops.
- The electric charge alarm indicator activates when there is a charging failure.

PRODUCT OVERVIEW

Operation of the Display's Buttons

Buttons

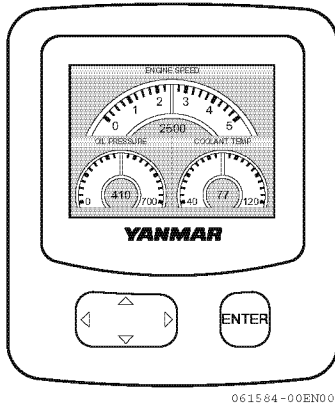

061584-00EN00

Figure 9

- Act on pop-up menu (MAIN MENU)
- Perform the function

- ▲ Up Arrow moves menu selection up
- ▼ Down Arrow moves menu selection down
- ◀ Left Arrow acts on current menu item
- ▶ Right Arrow acts on current menu item

Hot Key List

Item	Operation	Indication
MAIN MENU	Press the [ENTER] button.	Display MAIN MENU.
MENU LAYER SKIP	Hold the ◀ button down for 1 second.	Close MENU and return to the normal screen.
ICON INFO	Press the ▼ button while the icon with a detail information indication function is displayed.	Display the related setting screen of the relevant icon. If there are multiple items, execute with the [ENTER] button after selecting with the ◀ ▶ buttons.
Adjusting Brightness	Press the ▲ button.	Display the brightness adjustment screen and adjust brightness with the ▲ ▼ buttons.
Switching Night Mode	Press the ◀ button.	Switch to the night mode indication.
Setting Complete	Hold the [ENTER] button down for 1 second while the ◀ icon is highlighted.	Close the setting screen and MENU and return to the normal indication.
Switching Monitor Display Indication	Press the ▶ button.	Switch to the monitor screen in the normal indication. Send the screen in order with the ◀ ▶ buttons. The monitor screen is fixed when there is no operation with the ◀ ▶ buttons for 5 seconds.

Switch Panel (to start and stop the engine)

The switch panel has the following functions.

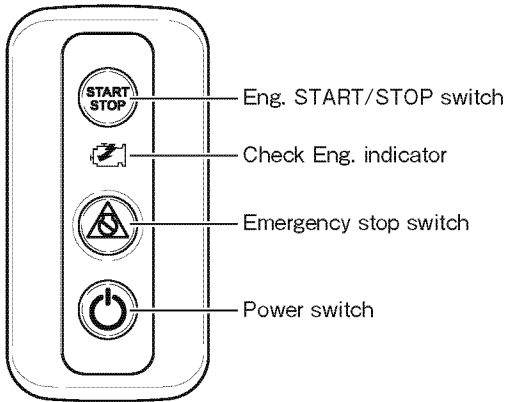

037627-00B00

Figure 10

To start and stop the engine:

Press the START/STOP switch.

Emergency Stop Switch

Use this switch only in an emergency.

NOTICE

Under normal circumstances, do not use the Emergency stop switch to stop the engine.

The engine shuts down suddenly when the Emergency stop switch is pressed. After the engine has stopped, press the Emergency stop switch to release the emergency stop.

This Page Intentionally Left Blank

BEFORE YOU OPERATE

INTRODUCTION

This section of the *Operation Manual* describes the diesel fuel, engine oil and engine coolant specifications and how to replenish them.

SAFETY PRECAUTIONS

Before performing any operations within this section, review the *Safety section on page 3*.

BEFORE YOU OPERATE

DIESEL FUEL

Diesel Fuel Specifications

WARNING

Fire and Explosion Hazard.
Diesel fuel is flammable and explosive under certain conditions.

Only use diesel fuels recommended by Yanmar for the best engine performance, to prevent engine damage and to comply with EPA warranty requirements. Only use clean diesel fuel.

Diesel fuel should comply with the following specifications. The table lists several worldwide specifications for diesel fuels.

DIESEL FUEL SPECIFICATION	LOCATION
ASTM D975 No. 2-D S15, No. 1-D S15	USA
EN590-2009	European Union
ISO 8217 DMX	International
BS 2869-A1 or A2	United Kingdom
JIS K2204 Grade No. 2	Japan

Biodiesel Fuels

Yanmar approves the use of biodiesel fuels that do not exceed a blend of 7% non-mineral oil based fuel with 93% standard diesel fuel. Such biodiesel fuels are known in the marketplace as B7 biodiesel fuels. B7 biodiesel fuel can reduce particulate matter and the emission of “greenhouse” gases compared to standard diesel fuel.

If the B7 biodiesel fuel used does not meet the approved specifications, it will cause abnormal wear of injectors, reduce the life of the engine and it may affect the warranty coverage of your engine.

B7 diesel fuels must meet certain specifications.

The biodiesel fuels must meet the minimum specifications for the country in which they are used:

- In Europe, biodiesel fuels must comply with the European Standard EN590-2009, EN14214.
- In the United States, biodiesel fuels must comply with the American Standard ASTM D-6751 Grade-S15, D7467 Grade B7-S15.

Biodiesel should be purchased only from recognized and authorized diesel fuel suppliers.

Precautions and concerns regarding the use of biofuels:

- Biodiesel fuels have a higher content of methyl-esters, which may deteriorate certain metal, rubber and plastic components of the fuel system. The customer and / or boat builder are responsible to verify the usage of biodiesel compatible components on the vessel fuel supply and return systems.
- Free water in biodiesel may result in plugging of fuel filters and increased bacterial growth.
- High viscosity at low temperatures may result in fuel delivery problems, injection pump seizures and poor injection nozzle spray atomization.
- Biodiesel may have adverse effects on some elastomers (seal materials) and may result in fuel leakage and dilution of the engine lubricating oil.

- Even biodiesel fuels that comply with a suitable standard as delivered will require additional care and attention to maintain the quality of the fuel in the equipment or other fuel tanks. It is important to maintain a supply of clean, fresh fuel. Regular flushing of the fuel system, and / or fuel storage containers, may be necessary.
- The use of biodiesel fuels that do not comply with the standards as agreed to by the diesel engine manufacturers and the diesel fuel injection equipment manufacturers, or biodiesel fuels that have degraded as per the precautions and concerns above, may affect the warranty coverage of your engine.

Additional Technical Fuel Requirements

- The fuel cetane number should be 45 or higher.
- The sulfur content must not exceed 0.5% by volume. Less than 0.05% is preferred. Especially in U.S.A. and Canada, Ultra Low sulfur fuel (≤ 15 ppm) must be used.
- Never mix kerosene, used engine oil or residual fuels with the diesel fuel.
- Water and sediment in the fuel should not exceed 0.05% by volume.
- Keep the fuel tank and fuel-handling equipment clean at all times.
- Ash content not to exceed 0.01% by volume.
- Carbon residue content not to exceed 0.35% by volume. Less than 0.1% is preferred.
- Total aromatics content should not exceed 35% by volume. Less than 30% is preferred.
- PAH (polycyclic aromatic hydrocarbons) content should be below 10% by volume.
- Do not use Biocide.
- Lubricity: Wear mark of WS1.4 should be Max. 0.016 in. (400 μm) at HFRR test.

Handling of Diesel Fuel

⚠ WARNING

Fire and Explosion Hazard. Only fill the fuel tank with diesel fuel. Filling the fuel tank with gasoline may result in a fire and will damage the engine. Never refuel with the engine running. Wipe up all spills immediately. Keep sparks, open flames or any other form of ignition (match, cigarette, static electric source) well away when refueling.

Fire and Explosion Hazard. Always put the diesel fuel container on the ground when transferring the diesel fuel from the pump to the container. Hold the hose nozzle firmly against the side of the container while filling it. This prevents static electricity buildup which could cause sparks and ignite fuel vapors.

1. Water and dust in the fuel may cause engine failure. When fuel is stored, be sure that the inside of the storage container is clean and dry, and that the fuel is stored away from dirt or rain.

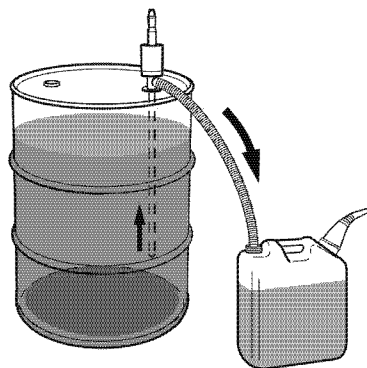

0004512

Figure 1

BEFORE YOU OPERATE

2. Keep the fuel container stationary for several hours to allow any dirt or water to settle to the bottom of the container. Use a pump to extract the clear, filtered fuel from the top of the container.

Fuel Tank (Optional)

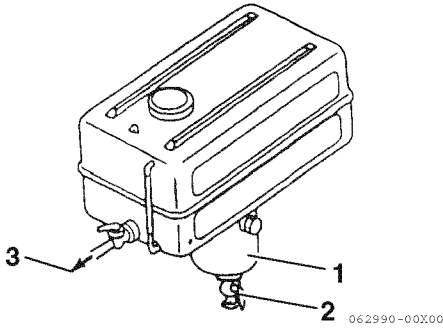

Figure 2

- 1 - Sediment Bowl
- 2 - Drain Cock
- 3 - Fuel Line to Engine

Install a drain cock (**Figure 2, (2)**) at the bottom of the fuel tank to remove water and contaminants from the sediment bowl (**Figure 2, (1)**).

The fuel outlet should be positioned 20 to 30 mm (0.79 to 1.18 in.) above the bottom of the tank so that only clean fuel is distributed to the engine.

Fuel System

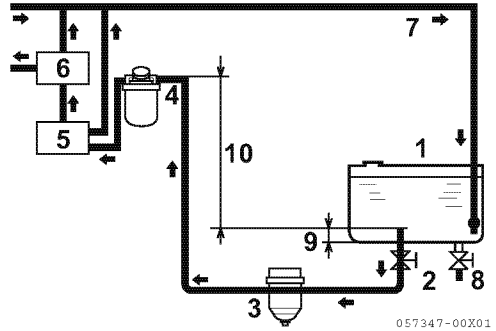

Figure 3

- 1 - Fuel Tank
- 2 - Fuel Cock
- 3 - Pre-filter (Water separator: Procured by customer)
- 4 - Fuel filter (with priming pump)
- 5 - Fuel supply pump
- 6 - Common rail
- 7 - Fuel return line
- 8 - Drain cock
- 9 - Approximately 20 to 30 mm (0.79 to 1.18 in.)
- 10 - Less than 500 mm (19.7 in.)

Install the fuel line from the fuel tank to the fuel injection pump as shown in **Figure 3**. The pre-filter (fuel/water separator: Optional) is installed at the intermediate section of that line.

Filling the Fuel Tank

Before filling fuel tank for the first time:

WARNING

Fire and Explosion Hazard.
Never refuel with the engine running.

Rinse fuel tank with kerosene or diesel fuel. Dispose of waste properly.

To fill the fuel tank:

WARNING

Fire and Explosion Hazard.
Operate bilge ventilation (blowers) for a minimum of 5 minutes to purge fumes from engine compartment after refueling. Never operate bilge blower while refueling. Doing so can pump explosive fumes into the engine compartment and result in an explosion.

1. Clean the area around the fuel cap.
2. Remove the fuel cap from the fuel tank.
3. Fill the tank with clean fuel free of oil and dirt.

WARNING

Fire and Explosion Hazard.
Hold the hose nozzle firmly against the filler port while filling. This prevents static electricity buildup which could cause sparks and ignite fuel vapors.

4. Stop fueling when the gauge shows the fuel tank is full.

WARNING

Fire and Explosion Hazard.
Never overfill the fuel tank.

5. Replace the fuel cap and hand-tighten. Over-tightening the fuel cap will damage it.

BEFORE YOU OPERATE

Bleeding the Fuel System

Bleeding must be done if any fuel system maintenance has been performed (replacement of fuel filter, etc.) or if the engine does not start after several attempts.

The fuel system needs to be primed under certain conditions:

- Before starting the engine for the first time.
- After running out of fuel and fuel has been added to the fuel tank.
- After fuel system maintenance such as changing the fuel filter and draining the fuel filter/water separator, or replacing a fuel system component.

WARNING

Fire and Explosion Hazard!

- Diesel fuel is flammable and explosive under certain conditions.
- Failure to comply could result in death or serious injury.

Exposure Hazard.

Always wear safety glasses when bleeding the fuel system.

Bleeding the fuel filter

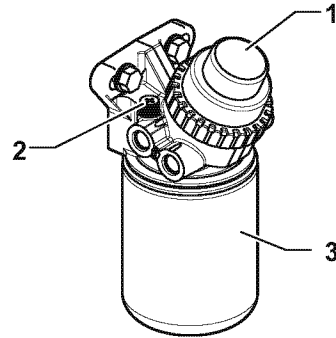

070312-00X00

Figure 4

- 1 – Priming Pump**
- 2 – Air Bleed Screw**
- 3 – Fuel filter element**

1. Check the fuel level in the fuel tank. Refill if necessary.
2. Open the fuel cock of the fuel tank.
3. Loosen the air bleed screw (**Figure 4, (2)**) two to three turns.
4. Push up and down on the priming pump (**Figure 4, (1)**) to release air out of the air bleed screw.
5. Continue pumping until a stream of fuel with no air bubbles begins to flow.
6. Tighten the air bleed screw.

NOTICE

Never use the starter motor to crank the engine in order to prime the fuel system. This may cause the starter motor to overheat and damage the coils, pinion and/or ring gear.

ENGINE OIL

Engine Oil Specifications

Using engine oil that does not meet or exceed the following guidelines or specifications may cause seizure of parts, abnormal wear and shorten engine life.

Service Categories

Use an engine oil that meets or exceeds the following guidelines and classifications:

- API Service Categories CD, CF, CF-4, CI and CI-4.
- SAE Viscosity:
15W-40. Engine oil 15W-40 can be used throughout the year.

NOTICE

- Be sure the engine oil, engine oil storage containers and engine oil filling equipment are free of sediment or water.
- Change the engine oil after the first 50 hours of operation and then at every 250 hours thereafter.
- Select the oil viscosity based on the ambient temperature where the engine is being operated. See the SAE Service Grade Viscosity Chart (**Figure 5**).
- Yanmar does not recommend the use of engine oil “additives”.

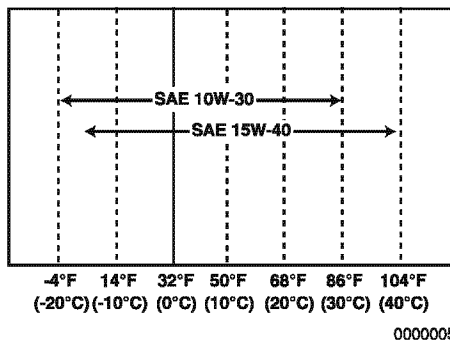

Figure 5

Handling Engine Oil

1. When handling and storing engine oil, be careful not to allow dust and water to contaminate the oil. Clean around the filler port before filling.
2. Do not mix lube oils of different types or brands. Mixing may cause the chemical characteristics of the oil to change and lubricating performance to decrease, reducing the engine's life.
3. Engine oil should be replaced at the specified intervals, regardless if the engine has been operated.

Engine Oil Viscosity

SAE 15W-40 is the recommended oil viscosities.

If you operate your equipment at temperatures outside the limits shown, consult your authorized Yanmar dealer or distributor for special lubricants or starting aids.

BEFORE YOU OPERATE

Checking the Engine Oil

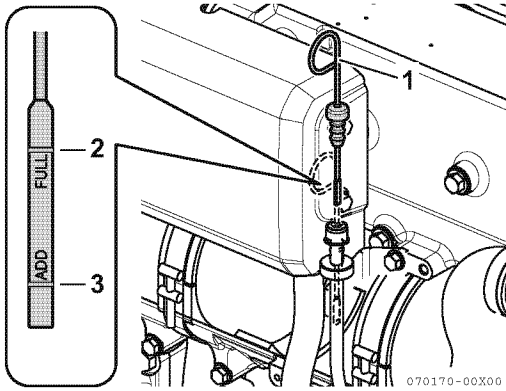

Figure 6

1. Make sure the engine is level.
2. Remove dipstick (**Figure 6, (1)**) and wipe with clean cloth.
3. Fully reinsert dipstick.
4. Remove dipstick. The oil level should be between upper (**Figure 6, (2)**) and lower (**Figure 6, (3)**) lines on the dipstick.
5. Add oil if necessary. See *Adding Engine Oil* on page 30.
6. Fully reinsert dipstick.

Adding Engine Oil

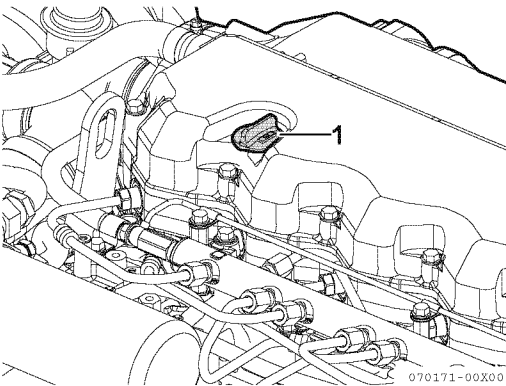

Figure 7

1. Remove the yellow oil filler port cap from filler port (**Figure 7, (1)**) and fill with engine oil.

NOTICE

Prevent dirt and debris from contaminating engine oil. Carefully clean the dipstick and the surrounding area before you remove the cap.

2. Fill with oil to the upper limit (**Figure 6, (2)**) on the dipstick (**Figure 6, (1)**).

NOTICE

Never overfill the engine with engine oil.

3. Insert the dipstick fully to check the level.

NOTICE

Always keep the oil level between upper and lower lines on the oil cap / dipstick.

4. Hand-tighten the filler port cap securely.

MARINE GEAR OIL

Note: Refer to the marine gear manufacturer's operation manual for the marine gear oil specifications.

Marine Gear Oil Specifications

Use marine gear oil that meets or exceeds the following guidelines and classifications:

KMH61A/KMH61V (Option)

- API Service Categories CD or higher
- SAE Viscosity #30

Checking Marine Gear Oil

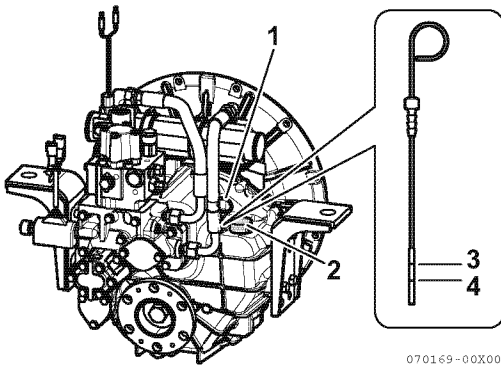

Figure 8

- 1 – Dipstick**
- 2 – Marine Gear Oil Filler Cap**
- 3 – Upper Limit**
- 4 – Lower Limit**

Note: KMH61A marine gear shown.

1. Make sure engine is level.
2. Remove the filler cap (**Figure 8, (2)**) at the top of the housing.
3. Remove dipstick (**Figure 8, (1)**) and wipe with clean cloth.
4. Fully reinsert dipstick.

5. Remove dipstick. The oil level should be between upper (**Figure 8, (3)**) and lower (**Figure 8, (4)**) lines on the dipstick.
6. Fully reinsert dipstick.

Adding Marine Gear Oil

1. Make sure the engine is level.
2. Remove the filler cap (**Figure 8, (2)**) at the top of the housing.
3. Fill with oil to the upper limit on the dipstick (**Figure 8, (3)**). See *Marine Gear Oil Specifications* on page 31.

NOTICE

Never overfill the marine gear with oil.

4. Fully reinsert the dipstick.
5. Tighten the filler port cap by hand.

ENGINE COOLANT

Engine Coolant Specifications

Note: In the U.S., LLC is required for the warranty to be valid.

- Texaco Long Life Coolant (LLC), both standard and premixed, product code 7997 and 7998
- Havoline Extended Life Antifreeze / Coolant, product code 7994

Following the manufacturer's recommendations, use a proper LLC which will not have any adverse effects on the materials (cast iron, aluminum, copper, etc.) of the engine's cooling system.

Always use the mixing ratios specified by the antifreeze manufacturer for the temperature range.

Coolant (Closed Cooling System)

NOTICE

Always add LLC to soft water especially when operating in cold weather. Never use hard water. Water should be clean and free from sludge or particles. Without LLC, cooling performance will decrease due to scale and rust in the coolant system. Water alone may freeze and form ice; it expands approximately 9% in volume. Use the proper amount of coolant concentrate for the ambient temperature as specified by the LLC manufacturer. LLC concentration should be a minimum of 30% to a maximum of 60%. Too much LLC will decrease the cooling efficiency. Excessive use of antifreeze also lowers the cooling efficiency of the engine. Never mix different types or brands of LLC, as a harmful sludge may form. Mixing different brands of antifreeze may cause chemical reactions, and may make the antifreeze useless or cause engine problems.

Checking and Adding Coolant

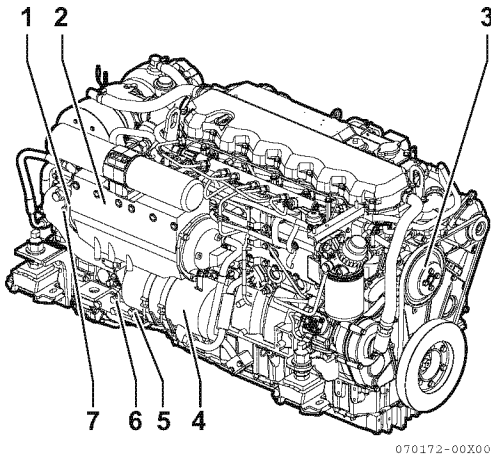

Figure 9

- 1 – Seawater drain cock
(Air cooler)**
- 2 – Air cooler**
- 3 – Coolant pump**
- 4 – Engine oil cooler**
- 5 – Seawater drain cock
(Engine oil cooler)**
- 6 – Coolant drain cock
(Cylinderblock)**
- 7 – Seawater drain cock
(Marine gear oil cooler)**

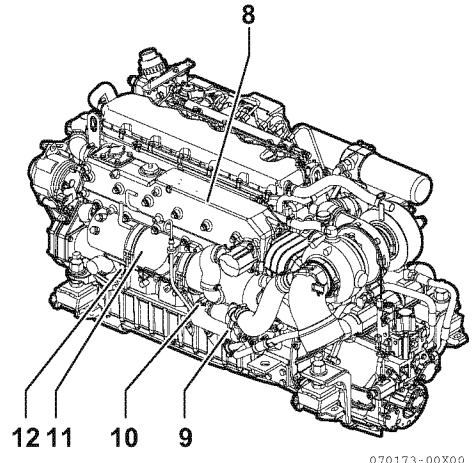

Figure 10

- 8 – Coolant tank**
- 9 – Seawater drain cock
(Heat exchanger)**
- 10 – Coolant drain cock
(Heat exchanger)**
- 11 – Heat exchanger**
- 12 – Seawater pump
(Drain from pump cover)**

BEFORE YOU OPERATE

1. Ensure all drain cocks are closed.

Note: The drain cocks are opened before shipping from the factory.

2. Loosen the filler cap of coolant tank to relieve the pressure, then remove the filler cap.

WARNING

Burn Hazard.

Never remove the coolant filler cap if the engine is hot. Steam and hot engine coolant will spray out and seriously burn you. Allow the engine to cool down before you attempt to remove the cap.

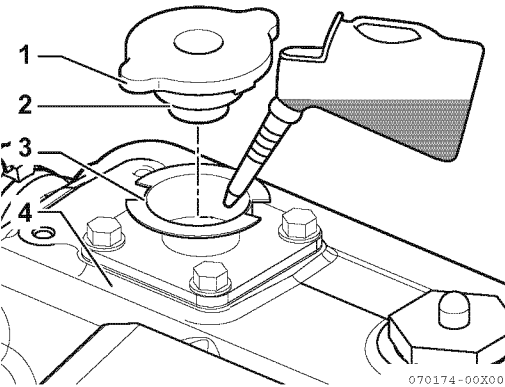

Figure 11

- 1 – Filler Cap Tabs
- 2 – Coolant Filler Cap
- 3 – Filler Port Notches
- 4 – Coolant Tank

3. Pour coolant slowly into coolant tank (**Figure 11, (4)**) to avoid air bubbles. Fill until coolant overflows from the filler port.

NOTICE

Never pour cold coolant into a hot engine.

4. Align filler cap tabs (**Figure 11, (1)**) with filler port notches (**Figure 11, (3)**) and tighten filler cap (**Figure 11, (2)**) firmly.

NOTICE

Always tighten coolant tank cap securely after checking coolant tank. Steam can spray out during engine operation if the cap is loose.

Note: The coolant level rises in the reservoir during operation. After stopping the engine, the coolant will cool down and the extra coolant will return to coolant tank.

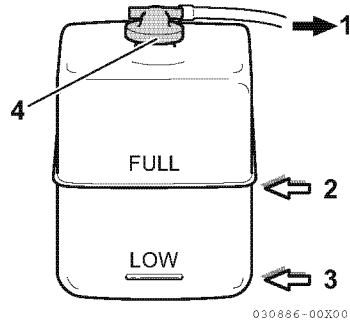

Figure 12

5. Check the coolant level in the reservoir. The level should be at the FULL mark (**Figure 12, (2)**). Add coolant if necessary.

NOTICE

Never pour cold coolant into a hot engine.

6. Remove reservoir cap (**Figure 12, (4)**) to add coolant if necessary. Do not add water.

7. Replace filler cap and tighten it firmly.
Failure to do so will cause water leakage.

Reservoir Capacity
1.5 L (1.59 qt)

8. Check the rubber hose (**Figure 12, (1)**) connecting the reservoir to coolant tank / heat exchanger. Replace if damaged.

Note: If the coolant runs low too often or the coolant level in coolant tank drops without any change in the level in the reservoir, there may be water or air leaks in the cooling system. Consult authorized Yanmar dealer or distributor.

This Page Intentionally Left Blank

ENGINE OPERATION

INTRODUCTION

This section of the *Operation Manual* describes the diesel fuel, engine oil and engine coolant specifications and how to replenish them. It also describes the daily engine checkout.

SAFETY PRECAUTIONS

Before performing any operations within this section, review the *Safety* section on page 3.

WARNING

Fire and Explosion Hazard



Never jump-start the engine. Sparks caused by shorting the battery to the starter terminals may cause a fire or explosion. Only use the start switch on the instrument panel to start the engine.

Sudden Movement Hazard

Be sure the boat is in open water away from other boats, docks or other obstructions before increasing engine speed. Avoid unexpected equipment movement. Shift the marine gear into the NEUTRAL position any time the engine is at idle.

To prevent accidental equipment movement, never start the engine in gear.

Sever Hazard



Keep children and pets away while the engine is operating.

NOTICE

If any indicator illuminates during engine operation, stop the engine immediately. Determine the cause and repair the problem before you continue to operate the engine.

If the alarm indicator with audible alarm fails to display and go out about 3 seconds after the ignition switch is turned on, consult authorized Yanmar Marine dealer or distributor for service before operating the engine.

If the vessel is equipped with a water lift (water lock) muffler, excessive cranking could cause seawater to enter the cylinders and damage the engine. If the engine does not start after cranking for 10 seconds, close the thru-hull water intake valve to avoid filling the muffler with water. Crank for 10 seconds at a time until the engine starts. When the engine does start, stop the engine immediately and turn off the switch.

Be sure to re-open the seacock and restart the engine. Operate the engine normally.

Observe the following environmental operating conditions to maintain engine performance and avoid premature engine wear:

- Avoid operating in extremely dusty conditions.
- Avoid operating in the presence of chemical gases or fumes.
- Never run the engine if the ambient temperature is above +40°C (+104°F) or below -16°C (+5°F).

NOTICE

- If the ambient temperature exceeds +40°C (+104°F), the engine may overheat and cause the engine oil to break down.
- If the ambient temperature is below -16°C (+5°F), rubber components such as gaskets and seals will harden causing premature engine wear and damage.
- Consult your authorized Yanmar Marine engine dealer or distributor if the engine will be operated outside of this standard temperature range.

Never engage the starter motor while the engine is running. Damage to the starter motor pinion and / or ring gear will result.

OPERATION (VC10: VESSEL CONTROL SYSTEM)**Starting the Engine**

1. Open the seacock (if equipped).
2. Open the fuel tank cock.
3. Turn the battery switch on for engine and engine control system.
4. Press the Power switch on the switch panel of the selected station (1, **Figure 1**).
 - The switch panel lamp will come on, and the control head (**Figure 2**) “SEL” lamp (**Figure 3**) will come on or flash.
 - To use the Engine START/STOP switch, be sure to turn the Power switch ON.

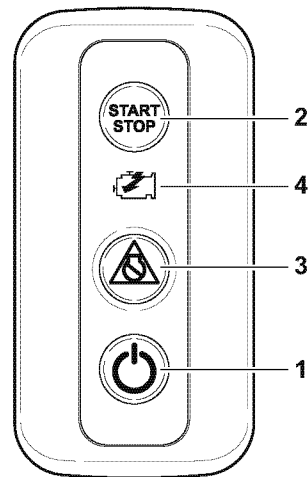

037627-00X01

Figure 1

5. If the “Sys on by ID” has been set, enter the password into the display.
6. Press the control head “SEL” switch.
 - Wait until the display shows the engine data. The display is shown.

ENGINE OPERATION

- If the “Start by ID” has been set, enter the password into the display.
 - The “Start by ID” has been set, the engine can be started in 10 seconds after entering the password into the display.
- Move the remote control handle to the N (Neutral) position.

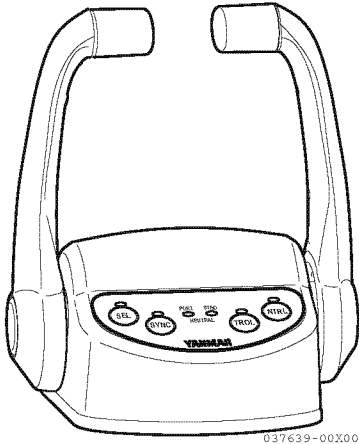

Figure 2

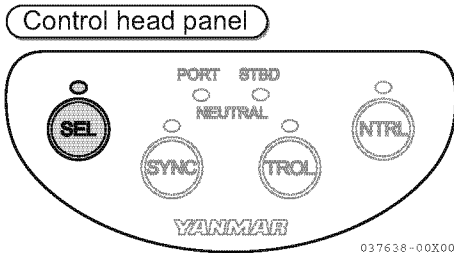

Figure 3

- Press the Engine START/STOP switch (2, **Figure 1**) and power on the starter.
 - When the engine starts, the VC10 display will show the screen with engine conditions (**Figure 4**).

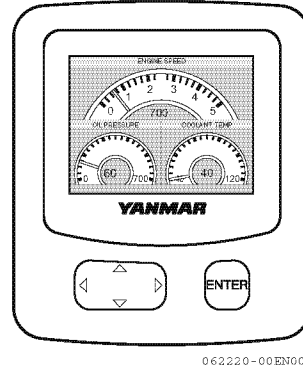

Figure 4

Note:

- Concerning the control head “SEL” lamp.
For Multi-Station: the “SEL” lamp will flash and for Single Station: the “SEL” lamp will come on.
- Pressing the Engine START/STOP switch when the “SEL” lamp is flashing allows the station to be selected as the engine is started.
- The engine will not start or stop if the Power switch is OFF. The Power switch must be ON at all times when the engine is running.
- Do not press the engine START/STOP switch except for stopping the engine.

Vessel Control System (VC10) has the following functions, which can be set in the Utility screen of MAIN MENU in the Digital Display. For more details, refer to the Vessel Control System Installation Manual.

Station Protect

It is a function to prevent the operation from the other stations while steering.

- Select “YES” to enable “Station protect”. The display and control head of that station can no longer be operated.
- Select “NO” or turn off the system power to disable “Station protect”.

Sys on by ID, Start by ID

It is a function to check ID for the purpose of anti-theft.

- If you select “YES” in “Sys on by ID”, it is necessary to enter the Owner ID on the display when turning on the system power. If you select “YES” in “Start by ID”, it is necessary to enter the owner ID on the display at engine start.
- The initial ID is “00000” and it can be changed with the below “Owner ID change” function.
- Even when the system power is turned off, the selected “Sys on by ID” and “Start by ID” cannot be disabled and it is required to enter the Owner ID at each time.
- After entering the ID and verification, if you don’t operate for 10 seconds, the entry becomes invalid and it is required to enter the Owner ID again.

Owner ID Change

The ID used in “Sys on by ID” and “Start by ID” can be set and changed as follows.

- If you select “Owner ID change”, the ID verification screen is displayed and you are asked to enter the current ID (Default: “00000”).
- If you enter the wrong ID 5 times, the ID is locked and you are no longer able to make an input. The lock can be released by turning off the system power.
- ID can be changed to any 5 digit number from 00000 to 99999.
- Select the number from 0 to 9 with the ▲ ▼ buttons. The fixed number is displayed by an asterisk when you press the ► button and the next digit is highlighted.
- Press the [ENTER] button after highlighting it with the ► button when all 5 digits are entered and the new ID becomes valid.

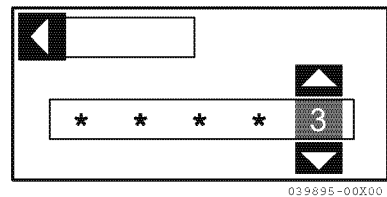

Figure 5

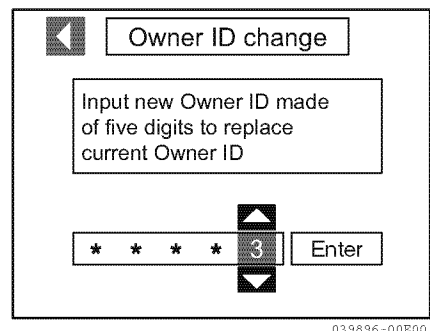

Figure 6

If the Engine Fails to Start

Before pressing the Start switch again, confirm that the engine has stopped completely. If the starter motor is operated before the engine has completely stopped, the starter motor pinion gear will be damaged.

NOTICE

Never hold for longer than 15 seconds or the starter motor will overheat.

Never attempt to restart the engine if the engine has not stopped completely. Pinion gear and starter motor damage will occur.

Note: Push and hold the start switch for a maximum of 15 seconds. If the engine does not start the first time, wait for about 15 seconds before trying again.

NOTICE

If the vessel is equipped with a water lift (water lock) muffler, excessive cranking could cause seawater to enter the cylinders and damage the engine. If the engine does not start after cranking for 15 seconds, close the thru-hull water intake valve to avoid filling the muffler with water. Crank for 10 seconds at a time until the engine starts. When the engine does start, stop the engine immediately and turn off the power switch. Be sure to re-open the seacock and restart the engine. Operate the engine normally.

Air Bleeding the Fuel System After Starting Failure

If the engine does not start after several attempts, there may be air in the fuel system. If air is in the fuel system, fuel cannot reach the fuel supply pump. Bleed the air out of the system. *See Bleeding the Fuel System on page 28.*

Starting at Low Temperatures

Comply with local environmental requirements. Do not use starting aids.

NOTICE

Never use an engine starting aid such as ether. Engine damage will result.

To limit white smoke, run the engine at low speed and under moderate load until the engine reaches normal operating temperature. A light load on a cold engine provides better combustion and faster engine warm-up than no load.

Avoid running the engine at idling speed any longer than necessary.

After the Engine has Started

After the engine has started, check the following items at a low engine speed:

1. Check that the gauges, indicators and alarm are normal.
 - Normal coolant operating temperature is approximately 71° to 85°C (160° to 185°F).
 - Normal oil pressure at 3000 min⁻¹ is 0.44 to 0.54 MPa (64 to 78 psi).
2. Check for water, fuel or oil leakage from the engine.
3. Check that the smoke color, engine vibration and sound are normal.

4. When there are no problems, keep the engine at low speed with the boat still stopped to distribute engine oil to all parts of the engine.
5. Check that sufficient seawater is discharged from the seawater outlet. Operation with inadequate seawater discharge will damage the impeller of the seawater pump. If seawater discharge is too low, stop the engine immediately. Identify the cause and repair.

NOTICE

The engine will seize if it is operated when seawater discharge is too small or if load is applied without any warming up operation.

**WARM UP MODE
(SHIFT DISCONNECT)**

1. Move the remote control handle to the N (Neutral) position. (The NEUTRAL lamp will come on)
2. Press the “NTRL” switch of the selected station control head.
3. The NEUTRAL lamp will come on, and the NEUTRAL lamp will flash.
4. Move the remote control handle. The engine speed can be controlled while the gear shift is in neutral.
5. Move the remote control handle to the N (Neutral) position, press the “NTRL” switch and cancel warm up mode.

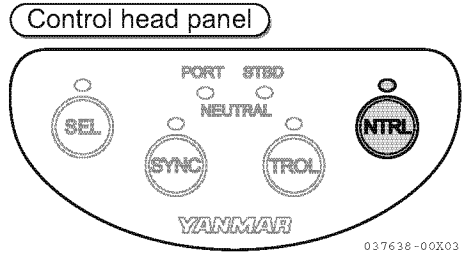

Figure 7

THROTTLE AND SHIFT CONTROL

⚠ WARNING

Sudden Movement Hazard

The boat will start to move when the marine gear is engaged:

- Ensure the boat is clear of all obstacles forward and aft.
- Quickly shift to the FORWARD position then back to the NEUTRAL position.
- Observe whether the boat moves in the direction you expect.

Neutral

1. Move the remote control handle to the N (Neutral) position. (The NEUTRAL lamp will come on)
2. When switching between forward and reverse, move the handle slowly between the forward and reverse positions. Move the handle firmly into either the forward or reverse position.

Forward

Move the handle toward F (forward) to the forward-side notch position. The engine will remain idling. Moving the handle forward further will increase the engine speed.

Reverse

Move the handle toward R (reverse) to the reverse-side notch position. The engine will remain idling. Pulling the handle back further will increase the engine speed.

Forward (Reverse) to Reverse (Forward)

Moving the handle quickly and switching from forward (reverse) to reverse (forward) will activate the gear shift delay (astern delay). The engine speed to decrease to idle speed for several seconds.

Note: The force required to move the throttle or shift handles can be adjusted with the Adjusting Screw.

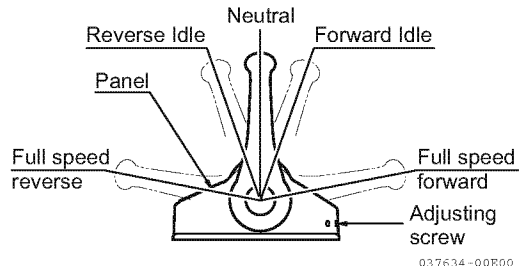

Figure 8

ENGINE SPEED LIMIT MODE

1. Move the remote control handle to the Forward Idle position. (Both sides in the case of twin engine.)
2. Press the “NTRL” switch of the selected station. (The lamp above “NTRL” switch will flash.)
3. Even if you tilt the handle to accelerate, the engine speed increases only up to the setting value.
4. Move the remote control handle to the N (Neutral), Forward Idle, or Reverse Idle position (both sides in the case of twin engine) and press the “NTRL” switch to release the [Engine Speed Limit Mode].

Note: The setting value can be set by the VC10 display. The default value is 50 %.

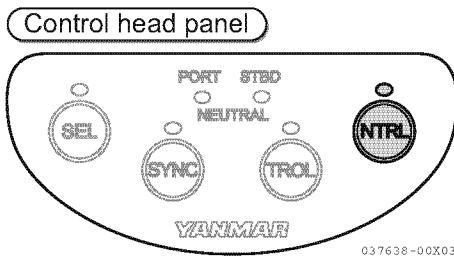

Figure 9

CAUTIONS DURING OPERATION

NOTICE

Engine trouble can arise if the engine is operated for a long time under overloaded conditions with the control handle in the full throttle position (maximum engine speed position), exceeding the continuous rated output engine speed. Operate the engine at about 100 min⁻¹ lower than the full throttle engine speed.

Note: If the engine is in the first 50 hours of operation, see New Engine Break-In on page 12 .

Always be on the lookout for problems during engine operation.

Pay particular attention to the following:

- Is sufficient seawater being discharged from the exhaust and seawater outlet pipe?

If the discharge is small, stop the engine immediately; identify the cause and repair.

- Is the smoke color normal?

The continuous emission of black exhaust smoke indicates engine overloading. This shortens the engines life and should be avoided.

ENGINE OPERATION

- Are there abnormal vibrations or noise?

NOTICE

Excessive vibration may cause damage to the engine, marine gear, hull and onboard equipment. In addition, it causes able passenger and crew discomfort.

Depending on the hull structure, engine and hull resonance may suddenly become great at a certain engine speed range, causing heavy vibrations. Avoid operation in this speed range. If you hear any abnormal sounds, stop the engine and inspect.

- Alarm buzzer sounds during operation.

NOTICE

If any alarm indicator with audible alarm sound appears on the display during engine operation, stop the engine immediately. Determine the cause and repair the problem before you continue to operate the engine.

- Is there water, oil or fuel leakage, or are there any loose bolts?

Check the engine room periodically for any problems.

- Is there sufficient diesel fuel in the diesel fuel tank?

Replenish diesel fuel before leaving the dock to avoid running out of fuel during operation.

- When operating the engine at low speed for long periods of time, race the engine once every 2 hours.

NOTICE

Racing the engine: With the gear in NEUTRAL, accelerate from the low-speed position to the high-speed position and repeat this process about five times. This is done to clean out carbon from the cylinders and the fuel injection valve. Neglecting to race the engine will result in poor smoke color and reduce engine performance.

- If possible, periodically operate the engine at near maximum engine speed while underway. This will generate higher exhaust temperatures, which will help clean out hard carbon deposits, maintaining engine performance and prolonging the life of the engine.

NOTICE

Never turn off the battery switch (if equipped) or short the battery cables during operation. Damage to the electric system will result.

SHUT-DOWN THE ENGINE (STOPPING)

Stop the engine in accordance with the following procedures:

Normal Stopping

1. Move the remote control handle to the N (Neutral) position. (The NEUTRAL lamp will come on.)
2. Cool the engine down at low speed (below 1000 min⁻¹ (rpm)) for about 5 minutes.

NOTICE

For maximum engine life, Yanmar recommends that when shutting the engine down, you allow the engine to idle, without load, for 5 minutes. This will allow the engine components that operate at high temperatures, such as the turbo-charger and exhaust system, to cool slightly before the engine itself is shut down.

3. Press the Engine START/STOP switch on the switch panel of the selected station.
4. Press the Power switch and turn the power OFF.

CAUTION

Do not press the Engine START/STOP switch when the engine is stopped. The engine will restart.

5. Wait 6 seconds or more before turning the battery switch off for secure system settle down.

NOTICE

- Do not turn the battery switch off before turning the power switch off or immediately after turning off the power switch.
- Turning the battery switch off before secure system settle down may cause alarm to be set at the next activation by turning on the power switch. In an emergency situation, you can start the engine even if the alarm is set. In order to release above alarm, turn off the power switch and wait 6 seconds before turning the power switch on again.

6. Turn the battery switch off for engine and engine control system.
7. Close the fuel tank cock.
8. Close the seacock.

CAUTION

- **Be sure to close the seacock. Neglecting to close the seacock could allow water to leak into the boat and may cause it to sink.**
- **If seawater is left inside the engine, it may freeze and damage parts of the cooling system when the ambient temperature is below 0 °C (32 °F).**

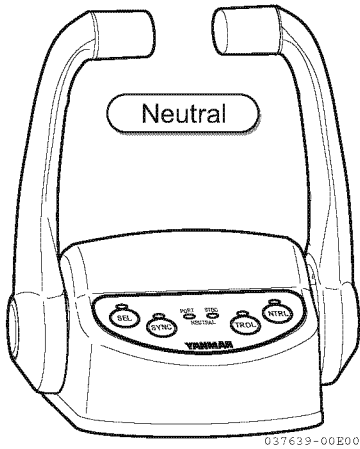

Figure 10

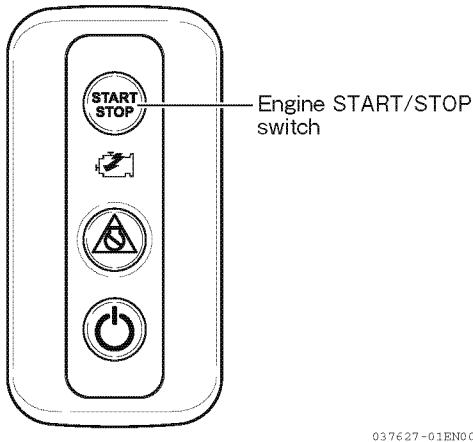

Figure 11

Emergency Stop

Electric Emergency Stop

NOTICE

Never use the Emergency Stop switch for a normal engine shutdown. Use this switch only when stopping the engine suddenly in an emergency.

1. Pressing the Emergency Stop switch on the switch panel will stop the engine immediately.
2. The Emergency Stop screen will be shown on the display, and the buzzer will sound.
3. After the engine has stopped, press the Emergency Stop switch to release the emergency stop. After releasing, it may take sometime to restart.

Note:

1. *The Emergency Stop switch should only be used in emergencies. Use the Engine START/STOP switch to stop the engine normally.*
2. *The engine cannot be started while the Emergency Stop switch is pressed (emergency stop mode not canceled).*

CONTROL THE BACKUP PANEL

WARNING

Only use this in an emergency.

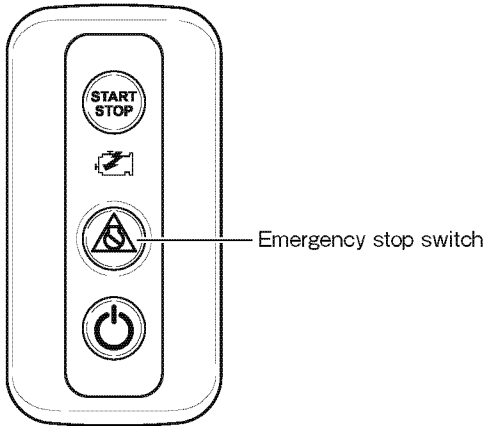

037627-01EN01

Figure 12

NOTICE

- In case of emergency, turning off the battery switch for the engine control unit can also stop the engine immediately.
- You can restart the engine but an alarm may be set up when the power switch is turned on. Unless you are in an emergency situation, in order to release above alarm, turn off the power switch and wait 6 seconds before turning the power switch on again.

1. Pull out the protect cover.
2. Check that the power switch on the switch panel is OFF and that the remote control handle is in the N (Neutral) position.
3. Press the power switch to the "ON" position on the backup panel. The lamp will come and control by the backup panel is enabled.
4. The engine can be started or stopped with the START/STOP switch.
5. Shift gears using the shift switch. (FWD: forward, NTRL: neutral, REV: reverse)
6. Adjust the engine speed using the sub throttle control volume. (anti-clockwise: lower engine speed, clockwise: raise engine speed)

When controlling the throttle, first move it fully anti-clockwise.

NOTICE

- The throttle and gear shift of the engine that has been turned on can be controlled.
- When controlling the throttle, always move it fully anti-clockwise first.
- Be sure to lower the engine speed by turning the sub throttle volume fully to anti-clockwise before stopping the engine.

NOTICE

- In case that the marine gear can not be shifted by remote control handle for some reason such as broken cable, remove the cable from shift lever on the marine gear and shift manually by turning the lever.

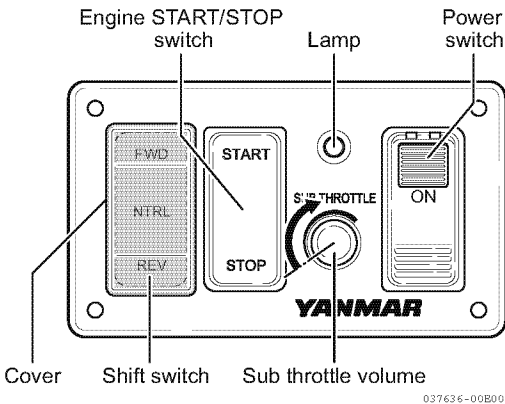

Figure 13

CHECKING THE ENGINE AFTER OPERATION

- Check that the power switch is off and that the battery switch (if equipped) is turned to off.
- Fill the fuel tank. *See Filling the Fuel Tank on page 27.*
- Close seawater cock(s).
- If there is a risk of freezing, check that the cooling system contains enough coolant. *See Engine Coolant Specifications on page 32.*
- If there is a risk of freezing, drain the seawater system. *See Drain Seawater Cooling System on page 92.*
- At temperatures below 0°C (32°F), drain seawater system and connect the engine heater (if equipped).

PERIODIC MAINTENANCE

INTRODUCTION

This section of the *Operation Manual* describes the procedures for proper care and maintenance of the engine.

SAFETY PRECAUTIONS

Before performing any maintenance procedures within this section, read the following safety information and *review the Safety section on page 3*.

WARNING

Crush Hazard



If the engine needs to be transported for repair, have a helper assist you attach it to a hoist and load it on a truck.

The engine lifting eyes are engineered to lift the weight of the marine engine only. Always use the engine lifting eyes when lifting the engine.

Additional equipment is necessary to lift the marine engine and marine gear together. Always use lifting equipment with sufficient capacity to lift the marine engine.

WARNING

Welding Hazard

- Always turn off the battery switch (if equipped) or disconnect the negative battery cable and the leads to the alternator when welding on the equipment.
- Remove the engine control unit multi-pin connector. Connect the weld clamp to the component to be welded and as close as possible to the welding point.
- Never connect the weld clamp to the engine or in a manner which would allow current to pass through a mounting bracket.
- When welding is completed, reconnect the alternator and engine control unit prior to reconnecting the batteries.

Entanglement Hazard



Never leave the power switch on when you are servicing the engine. Someone may accidentally start the engine and not realize you are servicing it.

Shock Hazard



Always turn off the battery switch (if equipped) or disconnect the negative battery cable before servicing the equipment.

Always keep the electrical connectors and terminals clean. Check the electrical harnesses for cracks, abrasions, and damaged or corroded connectors.

Never use undersized wiring for the electrical system.

Tool Hazard

Always remove any tools or shop rags used during maintenance from the area before operation.

NOTICE

Any part which is found defective as a result of inspection, or any part whose measured value does not satisfy the standard or limit, must be replaced.

Modifications may impair the engine's safety and performance characteristics and shorten the engine's life. Any alterations to this engine may void its warranty. Be sure to use Yanmar genuine replacement parts.

PRECAUTIONS

The Importance of Periodic Maintenance

Engine deterioration and wear occur in proportion to the length of time the engine has been in service and the conditions the engine is subjected to during operation. Periodic maintenance prevents unexpected downtime, reduces the number of accidents due to poor machine performance and helps extend the life of the engine.

Performing Periodic Maintenance

WARNING

Exhaust Hazard.

Never block windows, vents, or other means of ventilation if the engine is operating in an enclosed area. All internal combustion engines create carbon monoxide gas during operation. Accumulation of this gas within an enclosure could cause illness or even death. Make sure that all connections are tightened to specifications after repair is made to the exhaust system. Failure to comply could result in death or serious injury.

The Importance of Daily Checks

The Periodic Maintenance Schedule assumes that the daily checks are performed on a regular basis. Make it a habit to perform daily checks before the start of each operating day. *See Daily Checks on page 62.*

Keep a Log of Engine Hours and Daily Checks

Keep a log of the number of hours the engine is run each day and a log of the daily checks performed. Also note the date, type of repair (e.g., replaced alternator) and parts used for any service needed between the periodic maintenance intervals. Periodic maintenance intervals are every 50, 250, 500 and 1000 engine hours. Failure to perform periodic maintenance will shorten the life of the engine.

NOTICE

Failure to perform periodic maintenance will shorten the life of the engine and may void the warranty.

Yanmar Replacement Parts

Yanmar recommends that you use genuine Yanmar parts when replacement parts are needed. Genuine replacement parts help ensure long engine life.

Tools Required

Before you start any periodic maintenance procedure, make sure you have the tools you need to perform all of the required tasks.

Consult Your Authorized Yanmar Marine Dealer or Distributor for Help

Our professional service technicians have the expertise and skills to help you with any maintenance or service related procedures you need help with.

PERIODIC MAINTENANCE

Tightening Fasteners

Use the correct amount of torque when you tighten fasteners on the engine. Applying excessive torque may damage the fastener or component and not enough torque may cause a leak or component failure.

NOTICE



The tightening torque in the Standard Torque Chart should be applied only to the bolts with a “8.8” head (JIS strength classification: 8.8). Apply 60% torque to bolts that are not listed. Apply 80% torque when tightened to aluminum alloy.

Bolt Diameter x Pitch (mm)		M6x1.0	M8x1.25	M10x1.5	M12x1.75	M14x1.5	M16x1.5
Tightening Torque	N·m	10.8 ± 1.0	25.5 ± 3.0	49 ± 5.0	88.2 ± 10.0	140.0 ± 10.0	230.0 ± 10.0
	ft·lb	8.0 ± 0.7	18.8 ± 2.2	36.2 ± 3.7	65.1 ± 7.4	103 ± 7.2	170 ± 7.2

Taper Plugs		1/8	1/4	3/8	1/2
Tightening Torque	N·m	9.8	19.6	29.4	58.8
	ft·lb	7.4	14.5	21.7	43.2

When lock adhesive is applied, decide separately.

Pipe Joint Bolts		M8	M10	M12	M14	M16
Tightening Torque	N·m	14.7 ± 2	22.5 ± 3	29.4 ± 5	44.1 ± 5	53.9 ± 5
	ft·lb	10.9 ± 1.5	16.6 ± 2.2	21.7 ± 3.7	32.6 ± 3.7	69.8 ± 3.7

When seal washer applied, torque is 34 ± 5 N·m (25.1 ± 3.7 ft·lb).

EPA MAINTENANCE REQUIREMENTS

To maintain optimum engine performance and compliance with the Environmental Protection Agency (EPA) Regulations for Engines, it is essential that you follow the *Periodic Maintenance Schedule on page 58* and the *Periodic Maintenance Procedures on page 62* .

EPA Requirements for USA and Other Applicable Countries

The EPA emission regulation is applicable only in the USA and other countries that have adopted the EPA requirements in part or in whole. Determine and follow the emission regulations in the country where your engine will be operating to assist you in specified compliance.

PERIODIC MAINTENANCE

Environmental Condition for operation and maintenance

The following environmental operating conditions and maintenance should be observed, in order to keep engine performance.

- Ambient temperature: -5° to +40°C (23°F to +104°F)
- Relative humidity: 80% or lower

The diesel fuel should be:

- ASTM D975 No. 1-D S15, No. 2-D S15 or equivalent (minimum of cetane No. 45)

The lubricating oil should be:

- API Service Categories CD, CF, CF-4, CI and CI-4.

Be sure to perform inspections as outlined in *Periodic Maintenance Procedures* on page 62 and keep a record of the results.

Pay particular attention to these important points:

- Replacing the engine oil
- Replacing the engine oil filter
- Replacing the fuel filter
- Cleaning the intake silencer (air cleaner)

Note: Inspections are divided into two sections in accordance with who is responsible for performing the inspection: the user or the maker.

Inspection and Maintenance

See *Inspection and Maintenance of EPA Emission-Related Parts on page 61* for the EPA emission-related parts. Inspection and maintenance procedures not shown in *Inspection and Maintenance of EPA Emission-Related Parts on page 61* are covered in *Periodic Maintenance Schedule on page 58*.

This maintenance must be performed to keep the emission values of your engine in the standard values during the warranty period. The warranty period is determined by the age of the engine or the number of hours of operation.

Installation of Exhaust Sampling Port

All engines subject to emission standards shall be equipped with a connection in the engine exhaust system that is located downstream of the engine, and before any point at which the exhaust contacts water (or any other cooling / scrubbing medium), for the temporary attachment of gaseous and / or particulate emissions sampling equipment. This connection shall be internally threaded with standard pipe threads of a size not larger than 12.7 mm (0.5 in.), and shall be closed by a pipe plug when not in use. Equivalent connections are allowed.

The instructions for the proper installation and location of the required sample port, in addition to those specified above in the quoted federal regulation, are as follows:

1. The connection should be located as far downstream as reasonably practicable from any sharp bend (of 30 degrees or more) in the exhaust pipe to help ensure that a well-mixed exhaust flow sample may be taken;
2. The requirement that the connection be located before any point at which the exhaust contacts water (or any other cooling / scrubbing medium) does not include contact with water used to cool exhaust manifolds, unless the water is allowed to come into direct contact with the exhaust gases;
3. To allow ready access to the sample port, the connection should be located, if possible given the constraints of vessel design, approximately 0.6 to 1.8 m (2 to 6 ft) above a deck or walkway;
4. To facilitate insertion and withdrawal of an exhaust sample probe, there should be no obstructions for at least one and one-half exhaust pipe / stack diameters perpendicular, i.e., 90 degrees, from the sample port; and
5. If a threaded connection is used, both the internal and external threads should be coated with a high-temperature, anti-seize compound before the initial installation and at every subsequent re-installation to facilitate removal of the connection for testing.

PERIODIC MAINTENANCE SCHEDULE

Daily and periodic maintenance is important to keep the engine in good operating condition. The following is a summary of maintenance items by periodic maintenance intervals. Periodic maintenance intervals vary depending on engine application, loads, diesel fuel and engine oil used and are hard to establish definitively. The following should be treated only as a general guideline.

NOTICE

Establish a periodic maintenance plan according to the engine application and make sure to perform the required periodic maintenance at the intervals indicated. Failure to follow these guidelines will impair the engine's safety and performance characteristics, shorten the engine's life and may affect the warranty coverage on your engine.

Consult authorized Yanmar Marine dealer or distributor for assistance when checking items marked with a ●.

PERIODIC MAINTENANCE

○: Check or Clean ◇: Replace ●: Consult your authorized Yanmar Marine dealer or distributor

System	Item	Periodic Maintenance Interval					
		Daily <i>See Daily Checks on page 62.</i>	Every 50 hours or monthly whichever comes first	Every 250 hours or 1 year whichever comes first	Every 500 hours or 2 years whichever comes first	Every 1000 hours or 4 years whichever comes first	Every 2000 hours or 8 years whichever comes first
Whole	Visual inspection of engine exterior	○					
Fuel System	Check the fuel level and refill if necessary	○					
	Drain water and sediment from fuel tank		○ Initial 50	○			
	Drain the fuel / water separator		○				
	Replace the fuel filter element			◇			
Lubricating System	Check the lube oil level	○					
	Replace the lube oil		◇ Initial 50	◇			
	Replace the oil filter element		◇ Initial 50	◇			
	Cleaning the engine oil cooler						●
Cooling System (Seawater)	Seawater outlet	○ During Operation					
	Check or replace the seawater pump impeller			○		●	
	Check or replace the zinc anodes			◇			
	Check and clean the seawater passage					○	●
Cooling System (Coolant)	Check coolant level	○					
	Replace coolant	Every year. When Long Life Coolant is used, replace every 2 years. <i>See Engine Coolant Specifications on page 32.</i>					
	Check and clean the coolant passage						●

PERIODIC MAINTENANCE

○: Check or Clean ◇: Replace ●: Consult your authorized Yanmar Marine dealer or distributor

System	Item	Periodic Maintenance Interval					
		Daily <i>See Daily Checks on page 62.</i>	Every 50 hours or monthly whichever comes first	Every 250 hours or 1 year whichever comes first	Every 500 hours or 2 years whichever comes first	Every 1000 hours or 4 years whichever comes first	Every 2000 hours or 8 years whichever comes first
Air Intake and Exhaust System	Clean intake silencer (air cleaner) element			○			
	Clean or replace the exhaust / water mixing elbow			○			
	Wash the turbocharger blower			●			
Electrical System	Check the alarm and indicators	○					
	Check the electrolyte level in the battery		○				
	Adjust the tension of the alternator V belt or replace V belt			○		◇	
	Check the wiring connectors			○			
Engine Cylinder Head and Block	Check for leakage of fuel, engine oil and engine coolant	○ After starting					
	Adjust intake / exhaust valve clearance			● Initial 250		●	
Marine Gear	Check the lube oil level	Refer to the marine gear operation manual.					
	Replace the lube oil						
	Clean the oil strainer						
Miscellaneous Items	Replace rubberized hoses (fuel and water)	Replace every 2 years.					

Note: These procedures are considered normal maintenance and are performed at the owner's expense.

Inspection and Maintenance of EPA Emission-Related Parts

- 6LY400 and 6LY440 series are certified as EPA CI marine engines.

Inspection and Maintenance of EPA Emission-Related Parts for CI Marine Engines

Parts	Minimum Interval
Clean fuel injectors	1500 hours
Check fuel injectors	4500 hours
Check turbocharger adjustment	
Check electronic engine control unit and its associated sensors and actuators	

Note: Yanmar recommends that the inspection and maintenance items shown above be performed at an authorized Yanmar dealer or distributor.

PERIODIC MAINTENANCE

PERIODIC MAINTENANCE PROCEDURES

WARNING

Exposure Hazard.

Always wear personal protective equipment when performing periodic maintenance procedures.

Daily Checks

Before you head out for the day, make sure the Yanmar engine is in good operating condition.

NOTICE

It is important to perform the daily checks as listed in this Operation Manual. Periodic maintenance prevents unexpected downtime, reduces the number of accidents due to poor engine performance and helps extend the life of the engine.

Make sure you check the following items.

Visual Checks

1. Check for engine oil leaks.
2. Check for fuel leaks.

WARNING

Piercing Hazard.

Avoid skin contact with the high-pressure diesel fuel spray caused by a fuel system leak, such as a broken fuel injection line. High-pressure fuel can penetrate your skin and result in serious injury. If you are exposed to high-pressure fuel spray, obtain prompt medical treatment. Never check for a fuel leak with your hands.

Always use a piece of wood or

cardboard. Have your authorized Yanmar Marine dealer or distributor repair any damage.

3. Check for engine coolant leaks.
4. Check for damaged or missing parts.
5. Check for loose, missing or damaged fasteners.
6. Check the electrical harnesses for cracks, abrasions, and damaged or corroded connectors.
7. Check hoses for cracks, abrasions, and damaged, loose or corroded clamps.
8. Check the fuel filter / water separator for presence of water and contaminants. If you find any water or contaminants, drain the fuel filter / water separator. *See Draining Fuel Filter / Water Separator on page 65.* If you have to drain the fuel filter / water separator frequently, drain the fuel tank and check for the presence of water in your fuel supply. *See Draining the Fuel Tank on page 63.*

NOTICE

If any problem is noted during the visual check, the necessary corrective action should be taken before operating the engine.

Check Diesel Fuel, Engine Oil and Engine Coolant Levels

Follow the procedures in *Diesel Fuel on page 24*, *Engine Oil on page 29* and *Engine Coolant on page 32* to check these levels.

Checking and Refilling Marine Gear Oil

Refer to the *Operation Manual* for the marine gear.

Checking the Battery Electrolyte Level

Check the battery electrolyte level before use. See *Checking the Battery Electrolyte Level (Serviceable Batteries Only)* on page 66.

Checking the Alternator Belt

Check the belt tension before use. See *Checking and Adjusting the Alternator V-Belt Tension* on page 71.

Checking the Alarm Indicators

When operating the start switch on the instrument panel, check that there is no alarm message on the display and the alarm indicators work normally.

Preparing Fuel, Oil and Coolant in Reserve

Prepare sufficient fuel for the days operation. Always store engine oil and coolant in reserve (for at least one refill) onboard, to be ready for emergencies.

After Initial 50 Hours of Operation

Perform the following maintenance after the initial 50 hours of operation.

- **Draining the Fuel Tank**
- **Changing the Engine Oil and Replacing the Engine Oil Filter Element**

Draining the Fuel Tank

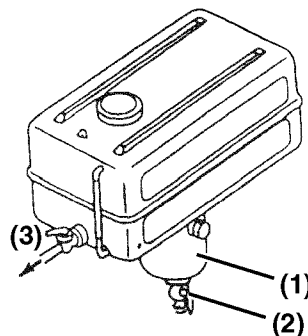

0004898

Figure 1

Note: Optional fuel tank shown. Actual equipment may differ.

1. Put a pan under the drain cock (**Figure 1, (1)**) to catch fuel.
2. Open the drain cock and drain water and sediment. Close the drain cock when the fuel is clean and free of air bubbles.

PERIODIC MAINTENANCE

Changing the Engine Oil and Replacing the Engine Oil Filter Element

The engine oil on a new engine becomes contaminated from the initial break-in of internal parts. It is very important that the initial oil replacement is performed as scheduled.

It is easiest and most available to drain the engine oil after operation while the engine is still warm.

⚠ WARNING

Burn Hazard.

If you must drain the engine oil while it is still hot, stay clear of the hot engine oil to avoid being burned. Always wear eye protection.

1. Turn the engine off.
2. Remove the engine oil dipstick. Attach the oil drain pump (if equipped) and pump out the oil.
For easier draining, remove the engine oil fill cap. Dispose of used oil properly.

NOTICE

- Prevent dirt and debris from contaminating engine oil. Carefully clean the dipstick and the surrounding area before removing the dipstick.
- Always be environmentally responsible.

3. Remove the engine oil filter (**Figure 2**) with a filter wrench (turn counterclockwise).

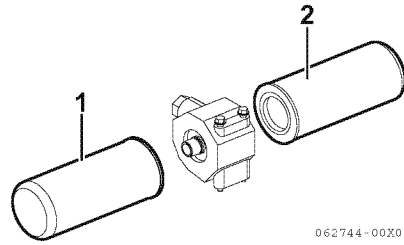

Figure 2

- 1 – Full Flow Engine Oil Filters**
2 – Bypass Engine Oil Filter

4. Install a new filter element and tighten by hand until the seal touches the housing.
5. Turn the filters an additional 3/4 to one turn with a filter wrench.
6. Fill with new engine oil. *See Adding Engine Oil on page 30.*

NOTICE

Never mix different types of engine oil. This may adversely affect the lubricating properties of the engine oil. Never overfill. Overfilling may result in white exhaust smoke, engine overspeed or internal damage.

7. Perform a trial run and check for oil leaks.
8. Approximately 10 minutes after stopping the engine, remove the oil dipstick and check the oil level. Add oil if the level is too low.

NOTICE

Be careful not to get any oil on the V-belt. Oil on the belt causes slipping and stretching. Replace the belt if it is damaged.

Every 50 Hours of Operation

Perform the following procedures every 50 hours thereafter or monthly, whichever comes first.

- **Draining Fuel Filter / Water Separator**
- **Checking Battery Electrolyte Level (Serviceable Batteries Only)**

Draining Fuel Filter / Water Separator

⚠ WARNING

Fire and Explosion Hazard.

When removing any fuel system component to perform maintenance (such as changing the fuel filter), put an approved container under the opening to catch the fuel.

Never use a shop rag to catch the fuel. Vapors from the rag are flammable and explosive. Wipe up any spills immediately.

Exposure Hazard.

Wear eye protection. The fuel system is under pressure and fuel could spray out when removing any fuel system component.

Water separator (Attach to Hull)

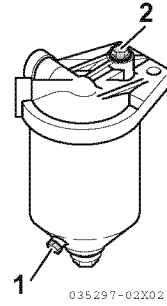

Figure 3

1. Close the fuel tank cock.
2. Loosen the drain plug (**Figure 3, (1)**) of the water separator and drain off any water or dirt collected inside. Dispose of the collected water and dirt properly.

NOTICE

Always be environmentally responsible.

3. After draining, tighten the air bleed screw (**Figure 3, (2)**).
4. Be sure to bleed air from the fuel system. See *Bleeding the Fuel System* on page 28.

PERIODIC MAINTENANCE

Checking the Battery Electrolyte Level (Serviceable Batteries Only)

⚠ WARNING

Exposure Hazard.

Batteries contain sulfuric acid. Never allow battery fluid to come in contact with clothing, skin or eyes. Severe burns could result. Always wear safety goggles and protective clothing when servicing the battery. If battery fluid contacts the eyes and / or skin, immediately flush the affected area with a large amount of clean water and obtain prompt medical treatment.

NOTICE

Never turn off the battery switch (if equipped) or short the battery cables during operation. Damage to the electric system will result.

Never operate with insufficient battery electrolyte. Operating with insufficient electrolyte will destroy the battery.

Battery fluid tends to evaporate in high temperatures, especially in summer. In such conditions, inspect the battery earlier than specified.

1. Turn off the battery switch (if equipped) or disconnect the negative (-) battery cable.
2. Do not operate with insufficient battery electrolyte, as the battery will be destroyed.
3. Remove the plugs and check the electrolyte level in all cells.

NOTICE

Never attempt to remove the covers or fill a maintenance-free battery.

4. If the level is lower than the minimum fill level (Figure 4, (1)), fill with distilled water (Figure 4, (2)) (available in the grocery store) up to the upper limit (Figure 4, (3)) of the battery.

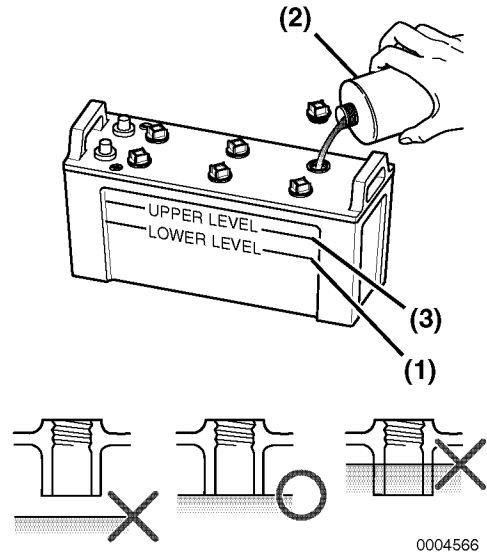

Figure 4

Note: The maximum fill level is approximately 10 to 15 mm (3/8 to 9/16 in.) above the plates.

After Initial 250 Hours of Operation

Perform the following maintenance after the initial 250 hours of operation.

- **Inspecting and Adjusting Intake / Exhaust Valve Clearance**

Inspecting and Adjusting Intake/Exhaust Valve Clearance

Proper adjustment is necessary to maintain the correct timing for opening and closing the valves. Improper adjustment will cause the engine to run noisily, resulting in poor engine performance and engine damage. Consult authorized Yanmar Marine dealer or distributor to adjust the intake / exhaust valve clearance.

Every 250 Hours of Operation

Perform the following maintenance every 250 hours or 1 year of operation, whichever comes first.

- **Draining the Fuel Tank**
- **Replacing the Fuel Filter Element**
- **Changing the Engine Oil and Replacing the Engine Oil Filter Element**
- **Check or replace the seawater pump impeller**
- **Checking or Replacing Zinc Anodes**
- **Cleaning the Intake Silencer (Air Cleaner) Element**
- **Cleaning the Exhaust / Water Mixing Elbow**
- **Wash the Turbocharger blower**
- **Checking and Adjusting the Alternator V-Belt Tension**
- **Checking the Wiring Connectors**

Draining the Fuel Tank

See Draining the Fuel Tank on page 63.

PERIODIC MAINTENANCE

Replacing the Fuel Filter Element

⚠ WARNING

Fire and Explosion Hazard.

When removing any fuel system component to perform maintenance (such as changing the fuel filter), put an approved container under the opening to catch the fuel.

Never use a shop rag to catch the fuel. Vapors from the rag are flammable and explosive. Wipe up any spills immediately.

Exposure Hazard.

Wear eye protection. The fuel system is under pressure and fuel could spray out when removing any fuel system component.

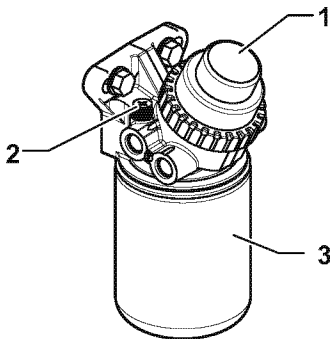

070312-00X00

Figure 5

1. Close the fuel tank cock.
2. Remove the cartridge filter (Figure 5, (3)) with a filter wrench.

Note: When removing the fuel filter, hold the bottom of the fuel filter with a cloth to prevent the fuel from spilling. Wipe up any spilled fuel immediately.

3. Apply a thin film of clean diesel fuel to the sealing surface of the new filter gasket.

Component	Part No.
Fuel filter element kit -	119581-55160

4. Install a new filter and hand-tighten. Use a filter wrench and tighten to 17.3 to 23.3 N·m (12.8 to 17.2 ft·lb).
5. Bleed the fuel system. See *Bleeding the Fuel System* on page 28. Dispose of waste properly.
6. Check for fuel leaks.

Changing the Engine Oil and Replacing the Engine Oil Filter Element

See *Changing the Engine Oil and Replacing the Engine Oil Filter Element* on page 64.

Checking or Replacing Seawater Pump Impeller

1. Loosen side cover bolts and remove the side cover.
2. Inspect the inside of the seawater pump with a flashlight. If any of the following are found, disassembly and maintenance are required:
 - Impeller blades are cracked or nicked. Edges or surfaces of the blades are marred or scratched.
 - Wear plate is damaged.
3. If no damage is found when inspecting the inside of the pump, install the O-ring and side cover.
4. If a large amount of water leaks continuously from the water drain line below the seawater pump during operation, replace the mechanical seal. Consult authorized Yanmar Marine dealer or distributor.

Replacing the Seawater Pump Impeller

Note: The impeller must be replaced periodically (every 1000 hours) even if there is no damage.

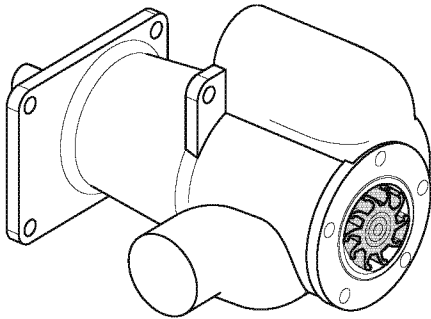

062687-00X00

Figure 6

There are two types of special service tools for removing the impeller:

Puller A (standard)

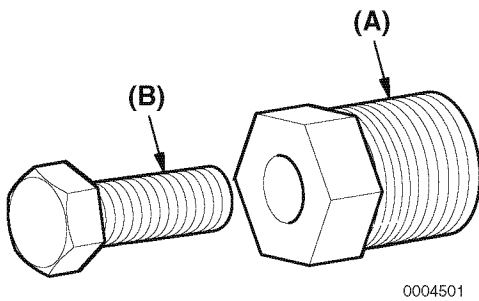

0004501

Figure 7

Puller A	Jack Screw B
M24x2	M10x40 mm length

1. Remove the side cover of the seawater pump.
2. Install puller **(Figure 7, (A))** in the impeller.
3. Turn the jack screw **(Figure 7, (B))** clockwise to remove the impeller from the pump body.

4. When installing the impeller, position blades of the impeller as shown in the illustration. **(Figure 9)**

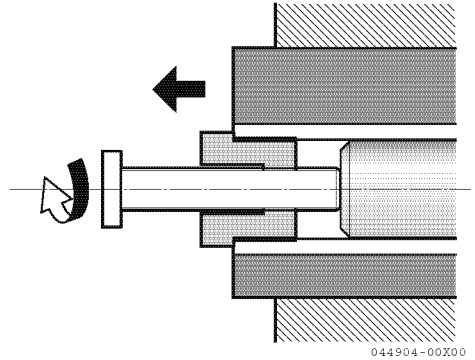

044904-00X00

Figure 8

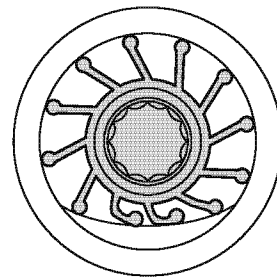

062690-00X00

Figure 9

*Note: When replacing a used impeller with a new one, the impeller must have an M24x2 thread **(Figure 8)**. Turn the M24 screw side of the impeller to the cover side and install.*

Checking or Replacing Zinc Anodes

Inspect and replace the zinc anodes periodically.

NOTICE

If zinc anodes are not replaced periodically, corrosion and engine damage will result.

PERIODIC MAINTENANCE

1. Close the seacock.
2. Drain the seawater cooling system. See *Drain Seawater Cooling System* on page 92.

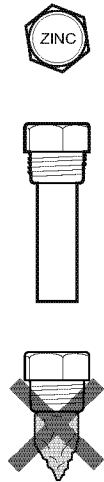

062662-01X00

Figure 10

3. Remove all the plugs (**Figure 11**), (**Figure 12**) and (**Figure 13**) labeled ZINC (**Figure 10**).
4. Measure the remaining zinc in the plug. Replace the zinc anode when it is less than one-half its original size. See chart for sizes.
5. Install a new zinc in a new plug.

NOTICE

Never use sealing tape to install the zinc anode. The anode must make metal-to-metal contact.

6. Install plug.
7. Open the seacock and check for leaks.

Heat exchanger

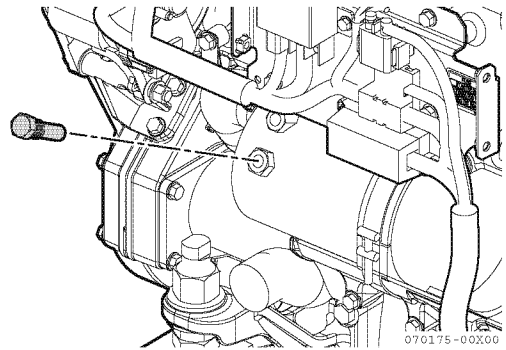

Figure 11

Engine oil cooler

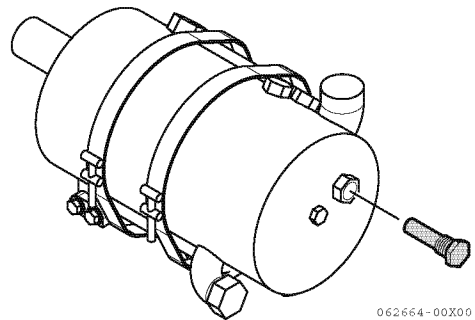

Figure 12

Air cooler

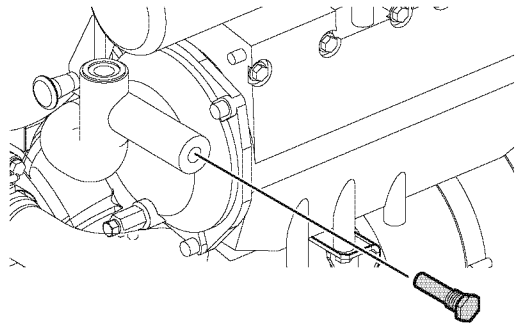

Figure 13

Note: Some marine gears have additional zinc anodes. Check the manufacturer's documentation for location and other information.

Cleaning the Intake Silencer (Air Cleaner) Element

1. Disassemble the intake silencer (air cleaner).
2. Remove element. Clean element and housing with a neutral detergent.
3. Dry completely and reassemble.

Cleaning the Exhaust / Water Mixing Elbow

The mixing elbow is attached to the turbocharger. The exhaust gas is mixed with seawater in the mixing elbow.

1. Remove the mixing elbow.
2. Clean dirt and scale out of the exhaust and seawater passages.
3. If the mixing elbow is damaged, repair or replace. Consult authorized Yanmar Marine dealer or distributor.
4. Inspect the gasket and replace if necessary.

Wash the Turbocharger blower

Contamination of the turbocharger causes revolutions to drop and engine output to fall.

If a significant drop in engine output is noted (10% or more), wash the turbocharger blower.

This should be done only by a trained and qualified technician. Consult authorized Yanmar Marine dealer or distributor.

Checking and Adjusting the Alternator V-Belt Tension

⚠ WARNING

Sever Hazard.

Perform this check with the power switch off and the battery switch turned off to avoid contact with moving parts.

NOTICE

- When there is not enough tension in the V-belt, it will slip and the coolant pump will fail to supply coolant. Engine overheating and seizure will result.
- When there is too much tension in the V-belt, the belt will become damaged more quickly and the coolant pump bearing may be damaged.
- Never get any oil on the belt(s). Oil on the belt causes slipping and stretching. Replace the belt if it is damaged.

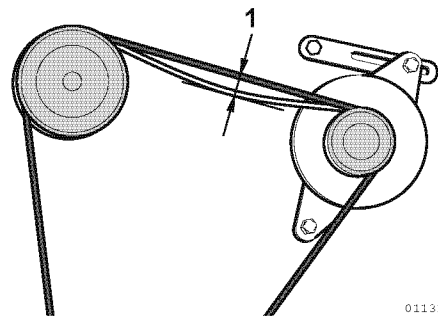

Figure 14

011317-01X02

1. Remove the belt cover.
2. Check the belt by pushing on the middle of the belt (**Figure 14, (1)**) with your finger.

With proper tension, the belt should deflect 8 to 10 mm (approximately 3/8 in.).

PERIODIC MAINTENANCE

3. Loosen the alternator bolt and move the alternator to adjust the V-belt tension.
4. Install the belt cover.

Note: If replacing the V-belt, loosen the V-pulley of the coolant pump to remove V-belt.

Checking the Wiring Connectors

Consult authorized Yanmar Marine dealer or distributor.

Every 1 Year of Operation

Perform the following maintenance every 1 year of operation.

- **Changing the Coolant**

Changing the Coolant

CAUTION

Coolant Hazard.

Wear eye protection and rubber gloves when you handle engine coolant. If contact with the eyes or skin should occur, flush eyes and wash immediately with clean water.

Change the coolant every year.

NOTICE

Never mix different types and / or colors of coolants.

Discard old coolant in an approved manner according to environmental laws.

Note: If Long Life coolant is used, replace coolant every 2 years.

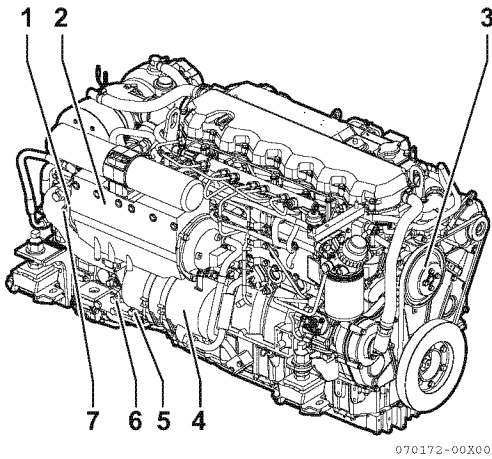

Figure 15

- 1 – Seawater drain cock
(Air cooler)
- 2 – Air cooler
- 3 – Coolant pump
- 4 – Engine oil cooler
- 5 – Seawater drain cock
(Engine oil cooler)
- 6 – Coolant drain cock
(Cylinderblock)
- 7 – Seawater drain cock
(Marine gear oil cooler)

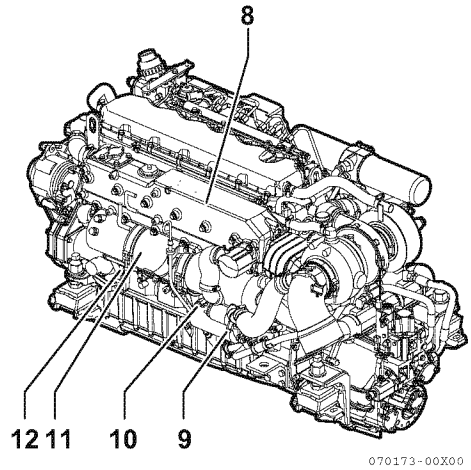

Figure 16

- 8 – Coolant tank
- 9 – Seawater drain cock
(Heat exchanger)
- 10 – Coolant drain cock
(Heat exchanger)
- 11 – Heat exchanger
- 12 – Seawater pump
(Drain from pump cover)

Note: The drain cocks are opened before shipping from the factory.

1. Open all coolant drain cocks.
2. Allow to drain completely. Dispose of waste properly.
3. Close all the drain cocks.
4. Fill coolant tank and reservoir with appropriate coolant.

See Engine Coolant Specifications on page 32 and Checking and Adding Coolant on page 33 .

Every 1000 Hours of Operation

Perform the following maintenance every 1000 hours or 4 years of operation, whichever comes first.

- **Replacing the Seawater Pump Impeller**
- **Cleaning and Checking the Seawater Passages**
- **Replacing the Alternator V belt**
- **Inspecting and Adjusting Intake / Exhaust Valve Clearance**

Replacing the Seawater Pump Impeller

The seawater impeller must be replaced every 1000 hours even if it is not damaged.

See Checking or Replacing Seawater Pump Impeller on page 68.

Cleaning and Checking the Seawater Passages

After prolonged use, clean the seawater passages to remove trash, scale, rust and other contaminants that collect in the cooling water passages. This can cause declining cooling performance. The following items need to be inspected:

- Heat Exchanger
- Pressure Cap

Consult authorized Yanmar Marine dealer or distributor.

Replacing the Alternator V belt

See Checking and Adjusting the Alternator V-Belt Tension on page 71.

Inspecting and Adjusting Intake/Exhaust Valve Clearance

Consult authorized Yanmar Marine dealer or distributor.

Every 2000 Hours of Operation

Perform the following maintenance every 2000 hours or 8 years of operation, whichever comes first.

- **Cleaning the Engine Oil Cooler**
- **Cleaning and Checking the Seawater Passages**
- **Check and Clean the Coolant Passage**

Cleaning the Engine Oil Cooler

Consult authorized Yanmar Marine dealer or distributor.

Cleaning and Checking the Seawater Passages

Consult authorized Yanmar Marine dealer or distributor.

Check and Clean the Coolant Passage

Consult authorized Yanmar Marine dealer or distributor.

Every 2 Years of Operation

Perform the following maintenance every 2 years of operation.

- **Replace Rubberized Hoses (Fuel and Water)**

Replace Rubberized Hoses (Fuel and Water)

The rubberized hoses (fuel and water) must be replaced every 2 years even if it is not damaged.

Consult authorized Yanmar Marine dealer or distributor.

This Page Intentionally Left Blank

TROUBLESHOOTING

SAFETY PRECAUTIONS

Before performing any troubleshooting procedures within this section, review the *Safety section on page 3*.

If a problem occurs, stop the engine immediately. Refer to the Symptom column in the Troubleshooting Chart to identify the problem.

TROUBLESHOOTING AFTER STARTING

Just after the engine has started, check the following items at a low engine speed:

Is sufficient water being discharged from the seawater outlet pipe?

If the discharge is low, stop the engine immediately. Identify the cause and repair.

Is the smoke color normal?

The continuous emission of black exhaust smoke indicates engine overloading. This shortens the engines life and should be avoided.

Are there abnormal vibrations or noise?

Depending on the hull structure, engine and hull resonance may suddenly increase at certain engine speed ranges, causing heavy vibrations. Avoid operation in this speed range. If any abnormal sounds are heard, stop the engine and inspect for cause.

Alarm sounds during operation.

If the alarm sounds during operation, lower the engine speed immediately, check the alarm indication and stop the engine for repairs.

Is there water, oil or fuel leakage? Are there any loose bolts or connections?

Check the engine room daily for any leaks or loose connections.

Is there sufficient fuel in the fuel tank?

Refill fuel in advance to avoid running out of fuel. If the tank runs out of fuel, bleed the fuel system. See *Bleeding the Fuel System on page 28*.

When operating the engine at low speed for long periods of time, race the engine once every 2 hours. Racing the engine with the clutch in NEUTRAL, accelerate from the low-speed position to the high-speed position and repeat this process about five times. This is done to clean out carbon from the cylinders and the fuel injection valves.

NOTICE

Neglecting to race the engine will result in poor smoke color and reduce engine performance.

Periodically operate the engine near maximum speed while underway. This will generate higher exhaust temperatures, which will help clean out hard carbon deposits, maintain engine performance and prolong the life of the engine.

TROUBLESHOOTING INFORMATION

If the engine does not operate properly, refer to the *Troubleshooting Chart on page 79* or consult authorized Yanmar Marine dealer or distributor.

Supply the authorized Yanmar Marine dealer or distributor with the following information:

- Model name and serial number of your engine
- Boat model, hull material, size (tons)
- Use, type of boating, number of hours run
- Total number of operation hours (refer to hour meter), age of boat
- DTC description that display is indicating.
- The operating conditions when the problem occurs:
 - Engine speed (min⁻¹)
 - Color of exhaust smoke
 - Type of diesel fuel
 - Type of engine oil
 - Any abnormal noises or vibration
 - Operating environment such as high altitude or extreme ambient temperatures, etc.
 - Engine maintenance history and previous problems
 - Other factors that contribute to the problem

TROUBLESHOOTING CHART

Symptom	Probable Cause	Measure
Indicators light on the instrument panel and alarm sounds during operation	Shift to low speed operation immediately, and check which indicator has come on. Stop the engine and inspect. If no abnormality is identified and there is no problem with operation, return to port at lowest speed and request repairs.	
Engine does not start or starts with difficulty		
Pinion gear does not engage	Loose terminal of battery/engage magnet	Tighten
	Poor contact of starting switch	Correct with sandpaper or replace
	Open coil of magnet switch	Replace
	Burr at gear tooth tip	Correct
	Poor clearance between pinion and ring gear	Correct
Pinion gear is engaged with ring gear, but does not rotate	Loose battery/starter terminal	Tighten
	Poor contact of starting switch	Correct with sandpaper or replace
	Worn brush	Replace
	Open circuit of starter coil	Replace
	Slippage of starter/clutch	Replace
	Excessive resistance of cable between battery and starter	Increase the cable size or shorten
	Insufficient battery charge	Charge
No fuel injection	Incomplete priming of fuel system	Carry out sufficient priming
	Clogged fuel inlet filter	Replace
	Fuel level in fuel tank is low	Add fuel
	Closed cock of fuel tank	Open cock
	Clogged fuel pipe	Clean
	Failure of fuel supply pump	Repair or replace
Failure of fuel injector	Faulty valve seat	Replace
	Sticking of nozzle	Replace
	Worn nozzle	Replace
	Clogged injection hole	Replace
Failure in fuel injection system	Loose fuel injection pipe joint	Tighten
	Broken fuel injection pipe	Replace
	Air trapped in fuel injection pipe	Bleed air from pipe
Engine compressed air leak	Air leak from exhaust valve	Carry out fitting of valve and seat
	Faulty gasket/packing	Replace
	Worn upper portion of cylinder	Replace
	Worn piston ring	Replace
	Sticking piston ring	Overhaul or replace
	Broken valve spring	Replace
Other	Failure of engine system	Conduct servicing
	Clogged intake or exhaust pipe	Clean
	Controller defects system error	Check DTC and conduct servicing
	Faulty starter relay	Replace
	The starter fuse (50A) is burned out	Check the wire harness connection and replace the fuse
	Gear position is not neutral	Shift neutral before engine start
	Emergency stop is active	Deactivate it

TROUBLESHOOTING

Symptom	Probable Cause	Measure
Engine is not running smoothly		
Operation failure of injection valve	Nozzle operation failure	Replace
	Broken fuel valve spring	Replace
Uneven fuel injection quantities	Clogged fuel filter	Replace
	Faulty operation of regulator valve	Replace
	Air trapped in fuel injection system	Bleed air from system and prime system
	Faulty operation of fuel supply pump	Repair
Other	Overload operation	Reduce load
	Moving parts seized	Disassemble, inspect and conduct servicing
	Slippage of gear box	Inspect and repair
Engine stops suddenly		
No fuel feed	Fuel level in fuel tank is low	Add fuel and prime
	Air trapped in fuel system or fuel injection	Bleed air
	Water trapped in fuel tank	Drain water from drain cock and fuel pipe, conduct priming
	Fuel cock closed	Inspect and repair as necessary
	Clogged fuel filter	Replace
	Broken fuel pipe	Replace
	Failure of fuel supply pump	Replace
Other	Moving parts seized	Disassemble and repair, or replace
	Controller defects system error	Inspect DTC and conduct servicing
Abnormal smoke color		
Failure of fuel injector	Clogged injection nozzle	Replace
	Sticking needle valve	Replace
	Reduction in injection pressure	Replace
	Poor atomization	Replace
	Carbon deposit	Clean
Turbo-charger failure	Clogged air filter	Clean
	Dirty compressor side	Clean
	Clogged turbine side	Clean
	Damaged bearing	Replace
Other	Overload operation	Reduce load
	Lubricant level too high	Lower the oil level
	Accumulated carbon deposit at intake/exhaust valve	Clean
	Dirty air cooler (If equipped)	Clean
	Improper fuel	Replace with proper fuel
	Clogged intake/exhaust valve	Clean

Symptom	Probable Cause	Measure
Insufficient output		
Insufficient fuel injection	Oil leak from fuel injection pipe joint	Tighten
	Clogged fuel filter	Replace
	Clogged fuel pipe	Clean
	Failure of fuel supply pump	Repair
Insufficient injection by fuel injection nozzle	Clogged injection hole	Replace
	Faulty valve seat	Replace
	Sticking nozzle	Replace
	Loose fuel injection pipe joint	Tighten
	Worn nozzle	Replace
Compressed gas leak in the engine cylinder	Gas leak from intake/exhaust valve	Conduct fitting of the valve
	Worn upper portion of cylinder bore	Lap or replace
	Worn piston ring	Replace
	Sticking piston ring	Overhaul or replace
Turbo-charger failure	Clogged air filter	Clean
	Dirty compressor side	Clean
	Clogged turbine nozzle	Clean
	Damaged bearing	Replace
Other	Improper fuel	Replace with correct fuel
	Clogged exhaust duct	Clean
	Seized or overheated moving parts	Disassemble and conduct servicing
	Insufficient seawater	Inspect seawater pump
	Insufficient feed of engine oil	Disassemble and clean engine oil pump and filter
	Controller defects system error	Inspect DTC and conduct servicing
Knocking		
Failure of fuel injector	Broken fuel valve spring	Replace
	Sticking nozzle	Replace
	Poor atomization	Replace
Other	Insufficient seawater	Replace seawater pump impeller
	Piston clearance excessive	Replace
	Bearing clearance excessive	Replace
	Improper fuel	Replace with correct fuel
	Water trapped in fuel	Replace fuel
	Poor compression	Inspect and service

TROUBLESHOOTING

Symptom	Probable Cause	Measure	
Breakdown of turbo-charger			
Drop in intake pressure	Dirty air filter	Clean	
	Leak from intake piping	Repair	
	Leak of exhaust gas	Repair	
	High intake air temperature	Complete thermal insulation of exhaust pipe	
		Ensure intake air path is unrestricted from outside air	
		Clean air filter	
	Drop in air pressure in engine room	Ensure intake air path is unrestricted from outside air	
	Broken turbine impeller	Replace	
	Dirty turbine impeller	Clean	
Clogged exhaust pipe	Clean		
Abnormal vibration	Broken turbine impeller	Replace	
	Broken compressor impeller	Replace	
	Deposit of carbon or oxides on turbine	Remove and repair or replace	
	Broken bearing	Replace	
	Bent turbine shaft	Replace	
	Loose parts or fasteners	Tighten	
Noise	Damaged bearing	Replace	
	Contact by revolving parts	Repair or replace	
	Dirty or carbon deposit on turbine and compressor	Clean	
	Entrapment of foreign matter (at turbine entrance)	Repair or replace	
	Rapid change in load (surging)	Stabilize the load or replace turbine nozzle	
Quick contamination of engine oil	Gas trapped in bearing housing	Repair	
	Clogged seal air path	Clean	
	Damaged seal ring	Replace	
	Clogged pressure balance path	Clean	
Pulsation of intake air pressure	Uneven cylinder combustion	Adjust for uniform combustion	
	Rapid change in load	Operate correctly	
	Excessively dirty compressor side	Clean	
	Intake temperature too high	Clean cooling fin	
		Complete thermal insulation of exhaust pipe	
Ensure intake air path is unrestricted from outside air			
Other	Bearing seizure	Replace	
	Corrosion in compressor/turbine impeller or bearing housing	Increase the coolant temperature	
Other malfunctions			
Noise generation	Loose flywheel set bolts	Tighten bolts	
	Loose connecting rod bolts	Tighten bolts	
	Worn crank pin	Replace	
	Excessive gear backlash	Inspect the gear; replace worn gear, shaft, and/or bushing with new ones	

Symptom	Probable Cause	Measure
Low lubrication oil pressure	Clogged engine oil filter	Replace
	Engine oil temperature too high	Check the seawater level
	Failure of oil pump	Overhaul or replace
	Faulty operation of oil pump relief valve	Tighten the adjusting valve
		Replace the safety valve
	Low viscosity of engine oil used	Replace the engine oil
	Insufficient engine oil quantity	Add oil
Faulty pressure switch	Replace	
Coolant temperature too high	Insufficient seawater	Check seawater system
	Faulty thermostat	Replace
	Loose drive belt of coolant pump	Adjust the belt tension
	Overloaded operation	Decrease the load
Low battery voltage	V belt is loose or broken	Replace V belt or adjust tension
	Battery is defective	Check battery fluid level, specific gravity or replace battery
	Alternator power generation failure	Consult authorized Yanmar Marine dealer or distributor
Instrument panel does not turn on, even though the power switch is turned on	No electrical current available. The battery switch for the engine control system is turned off, the fuse(10A) in the fuse box is burned out or the circuit is broken.	Consult authorized Yanmar Marine dealer or distributor
Other	Controller defects system error	Inspect and conduct servicing

FAILSAFE DIAGNOSIS FUNCTIONAL SPECIFICATION CHART

Fail-safe Actions

N Derate: Reduce engine speed to 2000min⁻¹ or less

Q Derate: Reduce amount of fuel consumption to -30%

	Display alarm	DTC	SPN	FMI	With FFD	DTC Description	Fail-safe Action				Note
							N Derate	Q Derate	ENG Stop	Other	
Engine-ECU	CHECK ENGINE	P0008	523249	5	-	Crank & Cam Shaft Speed Sensors Error - No signal	-	-	×	-	Suspicion of failure of the sensors or their wire connection.
	CHECK ENGINE	P0088	157	0	×	Rail Pressure Too High	×	-	-	-	Rail pressure is higher than usual value. Suspicion of failure of the fuel supply pump
	CHECK ENGINE	P0093	157	15	-	Rail Pressure Deviation Error - Higher Than The Target	×	×	-	-	Rail pressure is uncontrollable. Suspicion of failure of the fuel supply pump
	CHECK ENGINE	P0094	157	18	×	Rail pressure Deviation Error - Lower Than The Target	×	×	-	-	Rail pressure is uncontrollable. Suspicion of Fuel Leak on the high pressure line Suspicion of failure of the fuel supply pump
	CHECK ENGINE	P0117	110	4	-	Coolant Temperature Sensor Error - Low Range	-	-	-	-	Invalid signal from coolant temperature sensor. Suspicion of failure of the sensor or its wire connection.
	CHECK ENGINE	P0118	110	3	-	Coolant Temperature Sensor Error - High Range	-	-	-	-	Suspicion of failure of the sensor or its wire connection.
	MAIN THROTTLE	P0122	91	4	-	Main Analog Throttle Sensor 1 Error - Low Range	-	-	-	×	Invalid signal from main throttle sensor. Suspicion of failure of the sensor or wire connection.
	MAIN THROTTLE	P0123	91	3	-	Main Analog Throttle Sensor 1 Error - High Range	-	-	-	×	Engine speed temporary go down to low idle, and switch to backup throttle operation mode.
	CHECK ENGINE	P0168	174	0	×	Fuel Temperature Too High	-	×	-	-	Fuel temperature is higher than usual value. Suspicion of low level of fuel in tank.
	CHECK ENGINE	P0182	174	4	-	Fuel Temperature Sensor Error - Low Range	-	-	-	-	Invalid signal from fuel temperature sensor. Suspicion of failure of the sensor or its wire connection.
	CHECK ENGINE	P0183	174	3	-	Fuel Temperature Sensor Error - High Range	-	-	-	-	Suspicion of failure of the sensor or its wire connection.
	CHECK ENGINE	P0192	157	4	-	Rail Pressure Sensor Error - Low Range	×	×	-	-	Invalid signal from rail pressure sensor.
	CHECK ENGINE	P0193	157	3	-	Rail pressure Sensor Error - High Range	×	×	-	-	Suspicion of failure of the sensor or its wire connection.
	CHECK ENGINE	P0201	651	5	-	Injector 1 Error - Open/Short Circuit	×	×	-	-	Fuel injection malfunction is detected. Suspicion of failure of the injectors or their wire connection.
	CHECK ENGINE	P0202	652	5	-	Injector 2 Error - Open/Short Circuit	×	×	-	-	
	CHECK ENGINE	P0203	653	5	-	Injector 3 Error - Open/Short Circuit	×	×	-	-	
	CHECK ENGINE	P0204	654	5	-	Injector 4 Error - Open/Short Circuit	×	×	-	-	
	CHECK ENGINE	P0205	655	5	-	Injector 5 Error - Open/Short Circuit	×	×	-	-	
CHECK ENGINE	P0206	656	5	-	Injector 6 Error - Open/Short Circuit	×	×	-	-		

	Display alarm	DTC	SPN	FMI	With FFD	DTC Description	Failsafe Action				
							N Derate	Q Derate	ENG Stop	Other	Note
Engine-ECU	HOT ENGINE	P0217	110	0	×	Engine Coolant Temperature Too High	×	-	-	-	Coolant temperature is higher than usual value. Suspicion of failure of the engine cooling system.
	OVER REV	P0219	190	0	×	Engine Overspeed Condition	-	-	×	-	Engine speed exceeds the limit.
	SUB THROTTLE	P0227	29	4	-	Sub Throttle Sensor Error - Low Range	-	-	-	×	Invalid signal from backup throttle sensor. Suspicion of failure of the sensor or wire connection.
	SUB THROTTLE	P0228	29	3	-	Sub Throttle Sensor Error - High Range	-	-	-	×	Engine speed move to 1000 min ⁻¹ .
	TURBO BOOST	P0234	102	0	×	Charge Air Pressure Too High	-	×	-	-	Charge air pressure is higher than usual value. Suspicion of failure of the turbo charger or air piping system.
	CHECK ENGINE	P0237	102	4	-	Charge Air Pressure Sensor Error - Low Range	×	-	-	-	Invalid signal from charge air pressure sensor.
	CHECK ENGINE	P0238	102	3	-	Charge Air Pressure Sensor Error - High Range	×	-	-	-	Suspicion of failure of the sensor or its wire connection.
	CHECK ENGINE	P0336	522400	2	-	Crankshaft Speed Sensor Error - Irregular Signal	×	-	-	-	Invalid signal from crankshaft speed sensor.
	CHECK ENGINE	P0337	522400	5	-	Crankshaft Speed Sensor Error - No Signal	×	-	-	-	Suspicion of failure of the sensor or its wire connection.
	CHECK ENGINE	P0341	522401	2	-	Camshaft Speed Sensor Error - Irregular Signal	-	-	-	-	Invalid signal from camshaft speed sensor.
	CHECK ENGINE	P0342	522401	5	-	Camshaft Speed Sensor Error - No Signal	-	-	-	-	Suspicion of failure of the sensor or its wire connection.
	CHECK ENGINE	P0522	523552	4	-	Oil Pressure Sensor Error - Low Range	-	-	-	-	Invalid signal from oil pressure sensor.
	CHECK ENGINE	P0523	100	3	-	Oil Pressure Sensor Error - High Range	-	-	-	-	Suspicion of failure of the sensor or its wire connection.
	CHECK ENGINE	P0541	522243	6	-	Heater Relay Error - Short Circuit	-	-	-	-	Suspicion of failure of the heater relay or its wire connection.
	CHECK ENGINE	P0605	628	12	-	ECU Error - Abnormality CRC	-	-	×	-	ECU data error
	CHECK ENGINE	P0612	523010	5	-	EDU Relay 1 Error - Open Circuit	×	×	-	-	Suspicion of failure of the EDU relay 1 or its wire connection.
	CHECK ENGINE	P0627	633	5	-	Fuel Pump Error - Open Circuit	×	×	-	-	Suspicion of failure of the fuel supply pump or its wire connection.
	CHECK ENGINE	P0629	633	3	-	Fuel Pump Error - Short Circuit (VB - H)	×	×	-	-	
	CHECK ENGINE	P062D	2797	5	-	EDU 1 Error - Open Circuit	×	×	-	-	Suspicion of failure of the EDU1 or its wire connection.
	CHECK ENGINE	P062E	2798	5	-	EDU 2 Error - Open Circuit	×	×	-	-	Suspicion of failure of the EDU2 or its wire connection.
	CHECK ENGINE	P0652	523074	1	-	Sensor Power 1 Error - Short Circuit (GND)	-	-	-	-	Suspicion of failure of the wires toward sensors.
	CHECK ENGINE	P0653	523074	0	-	Sensor Power 1 Error - Short Circuit (VB)	-	-	-	-	Suspicion of failure of the wires toward sensors.
	CHECK ENGINE	P0666	1136	4	-	ECU Temperature Sensor Error - Low Range	-	-	-	-	Invalid signal from ECU temperature sensor. Suspicion of failure of the ECU.
CHECK ENGINE	P068B	1485	7	-	Main Relay Error - Stuck	-	-	-	-	Suspicion of failure of the main relay or its wire connection.	
CHECK ENGINE	P0698	523075	1	-	Sensor Power 2 Error - Short Circuit (GND)	-	-	-	-	Suspicion of failure of the wires toward sensors.	
CHECK ENGINE	P0699	523075	0	-	Sensor Power 2 Error - Short Circuit (VB)	-	-	-	-	Suspicion of failure of the wires toward sensors.	
CHECK ENGINE	P1004	523016	5	-	Accessory Relay Error - Open Circuit	-	-	-	-	Suspicion of failure of the Accessory relay or its wire connection.	

TROUBLESHOOTING

	Display alarm	DTC	SPN	FMI	With FFD	DTC Description	Failsafe Action				
							N Derate	Q Derate	ENG Stop	Other	Note
Engine-ECU	CHECK ENGINE	P1005	522778	7	-	Stop Switch Error - Stuck	-	-	-	-	Invalid signal from engine stop switch. Suspicion of failure of the stop switch or its wire connection.
	CHECK ENGINE	P1015	105	3	-	Charge Air Temperature Sensor Error - High Range	-	-	-	-	Invalid signal from charge air temperature sensor. Suspicion of failure of the sensor or its wire connection.
	CHECK ENGINE	P1016	105	4	-	Charge Air Temperature Sensor Error - Low Range	-	-	-	-	Suspicion of failure of the sensor or its wire connection.
	CHECK ENGINE	P1088	523072	7	×	Rail Pressure Too High - Exceed the limit	-	-	×	-	Rail pressure reaches to impermissible value. Suspicion of failure of the fuel supply pump
	CHECK ENGINE	P1146	2797	6	-	EDU 1 Error - Short Circuit	×	×	-	-	A number of fuel injection malfunction is detected. Suspicion of failure of the EDU1 or their wire connection.
	CHECK ENGINE	P1149	2798	6	-	EDU 2 Error - Short Circuit	×	×	-	-	A number of fuel injection malfunction is detected. Suspicion of failure of the EDU2 or their wire connection.
	OIL PRESSURE	P1198	100	1	×	Oil Pressure Too Low	×	-	-	-	Oil pressure is lower than usual value. Suspicion of failure of oil pump or oil leak
	CHECK ENGINE	P1235	1347	0	-	Fuel Pump Error - Protection Mode	×	×	-	-	High rail pressure condition is sustained. Engine shift into protection mode to avoid damage of fuel supply pump. Suspicion of failure of the fuel supply pump.
	CHECK ENGINE	P1236	1347	15	-	Fuel Pump Error - Replace Alarm	×	×	-	-	The phenomenon that are suspected of fuel supply pump malfunction have been detected repeatedly and continuously. Engine shift into protection mode to avoid more serious trouble. Replacement of the fuel supply pump is recommended.
	CHARGING SYSTEM	P1568	167	1	-	Charging System Error	-	-	-	-	Alternator does not generate power . Suspicion of failure of alternator or its wire connection.
	CHECK ENGINE	P1570	523631	7	-	Engine Turn Over	-	-	×	-	Engine overturn condition is detected. (Only in case that engine has turn over sensor)
	CHECK ENGINE	P1603	1136	0	-	ECU temperature Too High	-	-	-	-	ECU temperature is higher than usual value. Suspicion of failure of the ECU or high ambient temperature.
	CHECK ENGINE	P1604	1136	3	-	ECU Temperature Sensor Error - High Range	-	-	-	-	Invalid signal from ECU temperature sensor. Suspicion of failure of the sensor in ECU.
	BATTERY VOLTAGE	P160C	158	0	-	Battery Voltage Too High	-	-	-	-	Battery voltage is higher than usual value. Suspicion of failure of the alternator or battery cable connection.
	CHECK ENGINE	P160E	522576	12	-	ECU Error - EEPROM Memory Read	-	-	-	-	ECU data error
CHECK ENGINE	P1612	523017	5	-	EDU Relay 2 Error - Open Circuit	×	×	-	-	Suspicion of failure of the EDU relay 2 or its wire connection.	

	Display alarm	DTC	SPN	FMI	With FFD	DTC Description	Failsafe Action				Note
							N Derate	Q Derate	ENG Stop	Other	
Engine-ECU	CHECK ENGINE	P1630	523223	12	-	ECU Error - QR Code Checksum	×	×	-	-	ECU data error
	CHECK ENGINE	P1631	523221	12	-	ECU Error - No QR Code	×	×	-	-	ECU data error
	CHECK ENGINE	P1632	523221	13	-	ECU Error - Invalid QR Code	×	×	-	-	ECU data error
	BATTERY VOLTAGE	P1638	158	1	-	Battery Voltage Too Low	-	-	-	-	Battery voltage is lower than usual value. Suspicion of failure of the alternator or battery degradation
	CHECK ENGINE	P1641	522571	3	-	Fuel Pump Error - Short Circuit (VB - L)	×	×	-	-	Suspicion of failure of the fuel supply pump or its wire connection.
	CHECK ENGINE	P1642	633	6	-	Fuel Pump Error - Short Circuit (GND - H)	×	×	-	-	Suspicion of failure of the fuel supply pump or its wire connection.
	CHECK ENGINE	P2530	522308	7	-	Start Switch Error- Stuck	-	-	-	-	Invalid signal from engine start switch. Suspicion of failure of the start switch or its wire connection.
	LOW COOLANT LEVEL	P2560	111	1	-	Coolant Level Too Low	-	-	-	-	Coolant level is lower than usual. Suspicion of failure of coolant leak.
	MAIN THROTTLE	U0292	522596	9	-	CAN [*] Communication Error - TSC1	-	-	-	×	Engine lost the CAN communication. Suspicion of failure of Helm ECU or CAN wires connection.
	MAIN THROTTLE	U1304	459726	9	-	CAN Communication Error - Y_PM1	-	-	-	×	Engine speed temporary go down to low idle, and switch to backup throttle operation mode.
	MAIN THROTTLE	U0593	522596	19	-	CAN Throttle Signal Error - TSC1	-	-	-	×	Invalid main throttle signal via CAN communication. Suspicion of failure of Helm ECU.
	MAIN THROTTLE	U1305	459726	19	-	CAN Throttle Signal Error - Y_PM1	-	-	-	×	Engine speed temporary go down to low idle, and switch to backup throttle operation mode.
	DERATE MODE	-	-	-	-	-	(×)	(×)	-	-	Status indication. Engine is under derate mode.
	CYLINDER CUTOFF	-	-	-	-	-	-	-	-	-	Status indication. Engine is under cylinder cutoff mode.
BACK UP MODE	-	-	-	-	-	-	-	-	-	Status indication. Engine is under back up operation mode.	
STARTER INTERLOCK	-	-	-	-	-	-	-	-	-	Status indication. Neutral safety is active. Engine can not start.	
EMERGENCY STOP	-	-	-	-	-	-	-	-	-	Status indication. Emergency Stop is active. Engine can not start.	
Drive-ECU	DRIVE ECU DETECT FAILURE	P0920	773	3	-	SHIFT FORWARD H RANGE	-	-	-	-	-
	DRIVE ECU DETECT FAILURE	P0920	773	4	-	SHIFT FORWARD L RANGE	-	-	-	-	Shift Valve (F) shuts off
	DRIVE ECU DETECT FAILURE	P0924	784	3	-	SHIFT REVERSE H RANGE	-	-	-	-	-
	DRIVE ECU DETECT FAILURE	P0924	784	4	-	SHIFT REVERSE L RANGE	-	-	-	-	-

TROUBLESHOOTING

	Display alarm	DTC	SPN	FMI	With FFD	DTC Description	Failsafe Action				Note
							N Derate	Q Derate	ENG Stop	Other	
Drive-ECU	DRIVE ECU DETECT FAILURE	P0745	740	3	-	CHANGE VALVE H RANGE	-	-	-	-	-
	DRIVE ECU DETECT FAILURE	P0745	740	4	-	CHANGE VALVE L RANGE	-	-	-	-	Trolling function come to be unavailable
	DRIVE ECU DETECT FAILURE	P0720	191	8	-	PROP SPEED SENSOR L RANGE	-	-	-	-	C-type trolling function switched E-type
	DRIVE ECU DETECT FAILURE	P0218	177	0	-	GEAR OIL TEMP TOO HIGH	-	-	-	-	Trolling function come to be unavailable
	DRIVE ECU DETECT FAILURE	P0710	177	3	-	GEAR OIL TEMP H RANGE	-	-	-	-	-
	DRIVE ECU DETECT FAILURE	P0710	177	4	-	GEAR OIL TEMP L RANGE	-	-	-	-	-
	DRIVE ECU DETECT FAILURE	U103	525	10	-	CAN COM ERROR	-	-	-	-	Shift is changed to Neutral position
	DRIVE ECU DETECT FAILURE	U100	190	10	-	CAN COM ERROR ENGINE SPEED	-	-	-	-	-
	DRIVE ECU DETECT FAILURE	U404	525	2	-	CAN COM ERROR SHIFT	-	-	-	-	Shift is changed to Neutral position
	DRIVE ECU DETECT FAILURE	U402	684	2	-	CAN COM ERROR TROLLING	-	-	-	-	Trolling function come to be unavailable
	DRIVE ECU DETECT FAILURE	P0560	158	1	-	BATTERY VOLTAGE TOOL LOW	-	-	-	-	-
Helm-ECU	HELM ECU DETECT FAILURE	U100	523760	9	-	CAN COM ERROR ENG-ECU TO HELM-ECU	-	-	-	×	Station change comes to be unavailable
	HELM ECU DETECT FAILURE	U404	523761	9	-	CAN COM ERROR DRIVE-ECU TO HELM-ECU	-	-	-	×	Shift change comes to be unavailable
	HELM ECU DETECT FAILURE	U1201	523762	9	-	CAN COM ERROR HELM-ECU TO HELM-ECU	-	-	-	×	Station change comes to be unavailable
	HELM ECU DETECT FAILURE	U1202	523763	9	-	CAN COM ERROR HELM-LOCAL	-	-	-	×	Station change, Synch, Operation, Warm-up operation, and Engine speed limit mode come to be unavailable
	HELM ECU DETECT FAILURE	B1001	523543	4	-	NEUTRAL SW ACTIVATED	-	-	-	-	Station change, Synch, Operation, Warm-up operation, and Engine speed limit mode come to be unavailable
	HELM ECU DETECT FAILURE	B1002	523542	4	-	SELECT SW ACTIVATED	-	-	-	-	Station change and Indication dimming operation come to be unavailable
	HELM ECU DETECT FAILURE	B1003	523544	4	-	SYNCHRO SW ACTIVATED	-	-	-	-	Station change and Synchronization feature come to be unavailable
	HELM ECU DETECT FAILURE	B1004	523545	4	-	TROLL SW ACTIVATED	-	-	-	-	Station change and Trolling function come to be unavailable
HELM ECU DETECT FAILURE	B1005	523541	3	-	START/STOP SW ACTIVATED	-	-	-	-	Station change comes to be unavailable	

	Display alarm	DTC	SPN	FMI	With FFD	DTC Description	Failsafe Action				
							N Derate	Q Derate	ENG Stop	Other	Note
HELM-ECU	HELM ECU DETECT FAILURE	P0120	91	3	-	MAIN THROTTLE SENSOR H RANGE	-	-	-	×	Station change and Trolling function come to be unavailable
	HELM ECU DETECT FAILURE	P0120	91	4	-	MAIN THROTTLE SENSOR L RANGE	-	-	-	×	-
	HELM ECU DETECT FAILURE	B1020	91	13	-	THROTTLE CALIBRATION INCONSISTENCY	-	-	-	×	Station change function comes to be unavailable
	HELM ECU DETECT FAILURE	B1043	523768	12	-	HELM-ECU EEPROM ERROR	-	-	-	-	Station change comes to be unavailable
	HELM ECU DETECT FAILURE	U1207	522039	9	-	CAN COM ERROR SHIFT ACTUATOR	-	-	-	×	Shift is changed to Neutral position
	HELM ECU DETECT FAILURE	B1061	522040	11	-	SHIFT ACTUATOR FAILURE	-	-	-	×	-

*CAN: Controller Area Network

This Page Intentionally Left Blank

LONG-TERM STORAGE

If the engine will not be used for an extended period of time, special measures should be taken to protect the cooling system, fuel system and combustion chamber from corrosion and the exterior from rusting.

The engine can normally stand idle for up to 6 months. If it remains unused for longer than this, please consult your authorized Yanmar Marine dealer or distributor.

Before performing any storage procedures within this section, review the *Safety section on page 3*.

In cold temperatures or before long-term storage, be sure to drain the seawater from the cooling system.

NOTICE

- Do not drain the coolant system. A full coolant system will prevent corrosion and frost damage.
 - If seawater is left inside of the engine, it may freeze and damage parts of the cooling system when the ambient temperature is below 0°C (32°F).
-

PREPARE ENGINE FOR LONG-TERM STORAGE

Note: If the engine is close to a periodic maintenance interval, perform those maintenance procedures before putting the engine into long-term storage.

1. Wipe off any dust or oil from the outside of engine.
2. Drain water from fuel filters.
3. Drain fuel tank completely or fill the tank to prevent condensation.
4. Grease the exposed areas and joints of the remote control cables and the bearings of the remote control handle.
5. Seal the intake silencer, exhaust pipe, etc. to prevent moisture or contamination from entering engine.
6. Completely drain bilge in hull bottom.
7. Waterproof the engine room to prevent rain or seawater from entering.
8. Charge the battery once a month to compensate for battery's self-discharge.
9. Make sure the power switch is off.

DRAIN SEAWATER COOLING SYSTEM

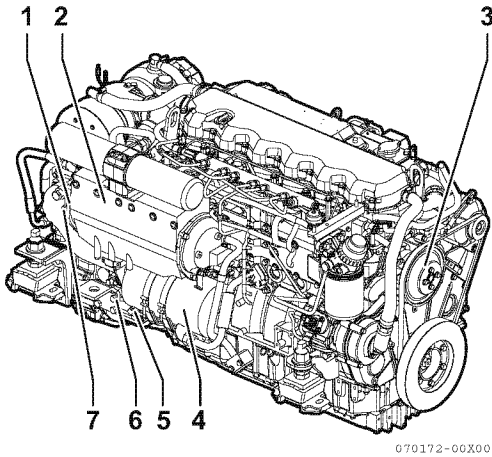

Figure 1

- 1 – Seawater drain cock (Air cooler)
- 2 – Air cooler
- 3 – Coolant pump
- 4 – Engine oil cooler
- 5 – Seawater drain cock (Engine oil cooler)
- 6 – Coolant drain cock (Cylinderblock)
- 7 – Seawater drain cock (Marine gear oil cooler)

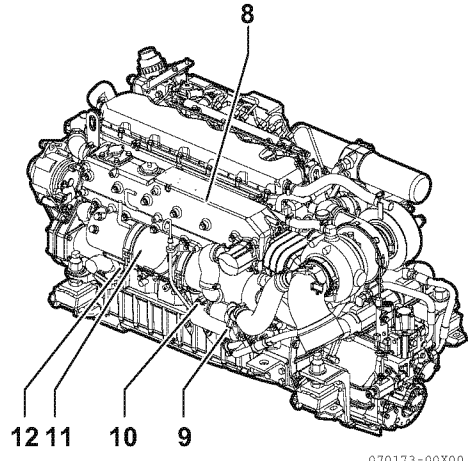

Figure 2

- 8 – Coolant tank
- 9 – Seawater drain cock (Heat exchanger)
- 10 – Coolant drain cock (Heat exchanger)
- 11 – Heat exchanger
- 12 – Seawater pump (Drain from pump cover)

Note: The drain cocks are opened before shipping from the factory.

NOTICE

If seawater is left inside, it may freeze and damage parts of the cooling system (heat exchanger, seawater pump, etc.) when ambient temperature is below 32°F (0°C).

1. Open the seawater drain cock on the clutch cooler (if equipped). Allow to drain. Open the seawater drain cock on the air cooler and drain. If no water drains, use a stiff brush to remove any debris.
2. Remove four bolts attaching the side cover of the seawater pump. Remove the cover and drain the seawater.
3. Install cover and tighten bolts.
4. Close all the drain cocks.

RETURNING THE ENGINE TO SERVICE

1. Replace the oil and the oil filter before running the engine.
2. Supply fuel if the fuel in the fuel tank was removed, and prime the fuel system.
3. Confirm that there is engine coolant in the engine.
4. Operate the engine at idle speed for 1 minute.
5. Check fluid levels and check engine for leaks.

This Page Intentionally Left Blank

SPECIFICATIONS

PRINCIPAL ENGINE SPECIFICATIONS

SPECIFICATIONS

6LY440/6LY400 Engine

Engine Model		6LY440	6LY400
Use		For recreational use	
Type		Vertical water cooled 4-cycle diesel engine	
Combustion System		Direct injection (Common rail system)	
Air Charging		Turbocharged with air cooler	
Number of Cylinders		6	
Bore x Stroke		105.9 mm x 110 mm (4.17 in. x 4.33 in.)	
Displacement		5.813 L (354.8 cu in.)	
Fuel stop power	Output at crankshaft/ engine speed	324 kW (440 hp metric) / 3300 min ⁻¹ *	294 kW (400 hp metric) / 3300 min ⁻¹ *
Installation		Flexible mounting	
Fuel Injection Timing		Variable timing (Electronic control)	
Fuel Injection Pressure		Variable pressure (Maximum injection pressure: 180 Mpa)	
Direction of Rotation (Crankshaft)		Counterclockwise viewed from flywheel side	
Cooling System		Coolant cooling with heat exchanger	
Lubrication System		Forced lubrication system	
Cooling Water Capacity (coolant)		Engine 20 L (21.1 qt), Reservoir: 1.5 L (1.6 qt)	
Lubricating Oil Capacity (engine)	Total**	20 L (21.1 qt)	
	Oil pan only	16.4 L (17.3 qt)	
	Effective***	8 L (8.5 qt)	
Starting System	Type	Electric	
	Starting motor	DC 12 V - 3 kW	
	AC generator	12 V - 80 A or 120 A (Option)	

* Rating Condition: Temperature of fuel; 40°C at fuel pump inlet; ISO 8665

** The "total" oil quantity includes oil in oil pan, channels, coolers and filter.

*** The effective amount of oil shows the difference in maximum scale of the dipstick and minimum scale.

Note: Density of fuel: 0.835 to 0.845 g/cm³ at 15°C. Fuel temperature at the inlet of the fuel injection pump.

Note: 1 hp metric = 0.7355 kW







Marine Gear Specifications

Model		KMH61A-2	KMH61V-2	Bobtail
Marine Gear	Down Angle	8°	12°	-
	Type	Hydraulic wet multiple disk clutch		-
	Direction of Rotation Propeller shaft (ahead) viewed from stern	Clockwise (Recommendation) or counterclockwise	Counterclockwise (Recommendation) or clockwise	-
	Reduction Ratio (forward/reverse)	1.55/1.55 2.04/2.04 2.43/2.43	1.24/1.24 1.49/1.49 1.98/1.98 2.43/2.43	-
	Lubricating Oil Capacity	2.8 L (3.0 qt)	7.5 L (7.9 qt)	-
	Dry Mass	58 kg (128 lb)	83.9 kg (185 lb)	-
Engine Dimension	Overall length	1440 mm (56.7 in.)		1287 mm (50.6 in.)
	Overall width	749 mm (29.4 in.)		723 mm (29.5 in.)
	Overall height	774 mm (30.5 in.)	897 mm (35.3 in.)	757 mm (29.8 in.)
Engine Dry Mass (including marine gear)		643 kg (1418 lb)	669 kg (1475 lb)	585 kg (1290 lb)

This Page Intentionally Left Blank

SYSTEM DIAGRAMS

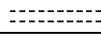
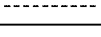
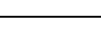
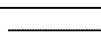
PIPING DIAGRAMS

Notation	Description
	Screw Joint (Union)
	Flange Joint
	Eye Joint
	Insertion Joint
	Drilled Hole
	Coolant Piping
	Cooling Seawater Piping
	Lubricating Oil Piping
	Diesel Fuel Piping

Note:

- Dimension of steel pipe: outer diameter x thickness.
- Dimension of rubber pipe: inner diameter x thickness.
- Fuel rubber pipes (marked *) satisfy EN/ISO7840.

6LY440/6LY400 with KMH61A/KMH61V Marine Gear

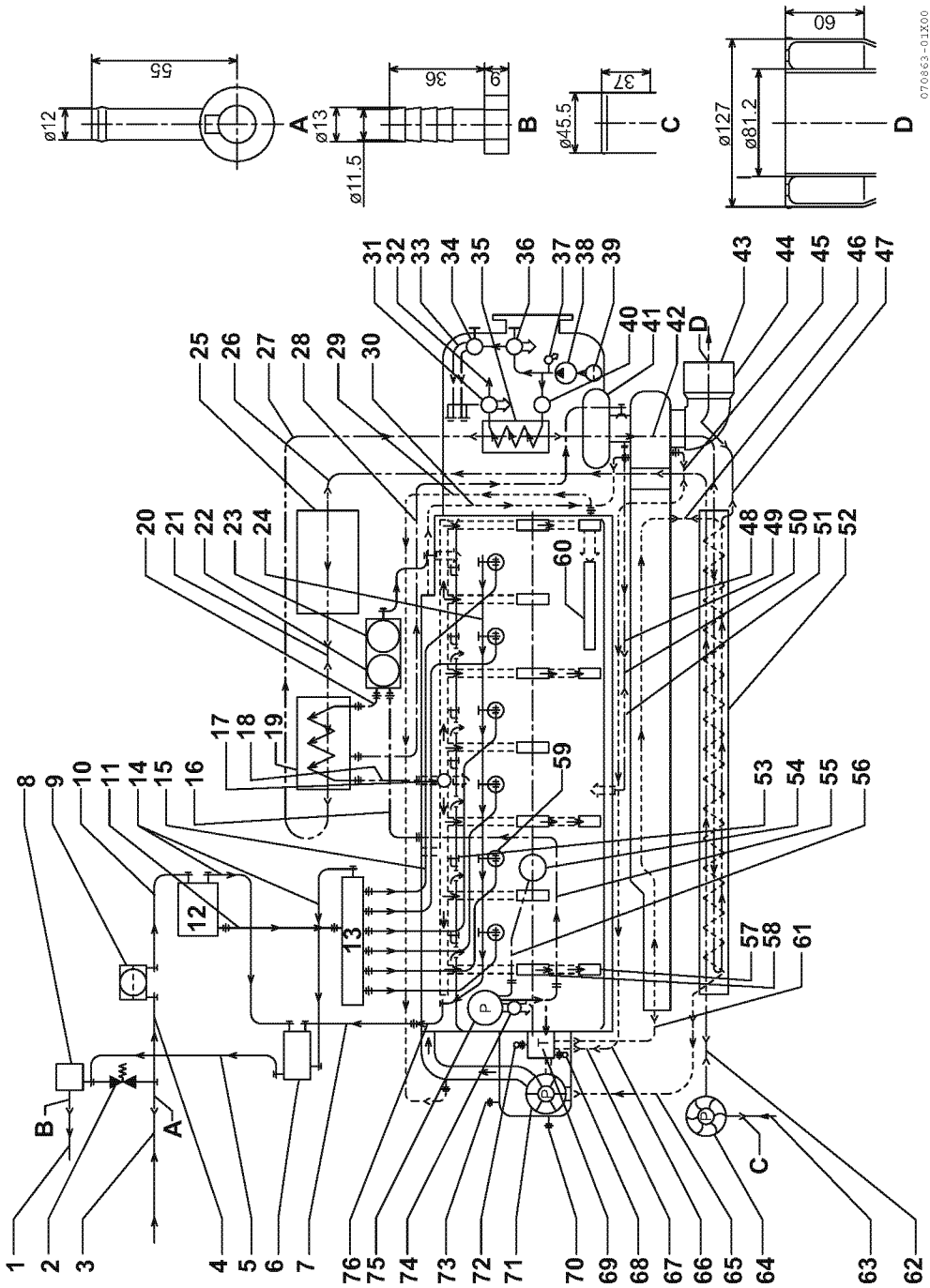

Figure 1

- | | |
|--|---|
| <ul style="list-style-type: none"> 1 – Fuel Overflow 2 – Relief Valve (Fuel Oil) 3 – Diesel Fuel Inlet 4 – $\varnothing 12 \times t1.2$ STPG 5 – $\varnothing 8 \times t1$ STS 6 – Fuel Pipe Mount 7 – $\varnothing 6 \times t0.7$ STS 8 – Fuel Oil Block 9 – Diesel Fuel Filter 10 – $\varnothing 10 \times t1.2$ STS 11 – $\varnothing 8 \times t2$ STS 12 – Fuel supply pump 13 – Common rail 14 – $\varnothing 4.76 \times t0.7$ Steel Pipe 15 – $\varnothing 8 \times t2$ STS 16 – Lubrication Oil Pipe
(SAE J526, SAE 100R14) 17 – Pressure Control Valve
(Engine) 18 – Lubrication Oil Pipe
(SAE J526, SAE 100R14) 19 – Engine oil cooler 20 – Lubrication Oil Pipe
(SAE J526, SAE 100R14) 21 – $\varnothing 38.1 \times t5$ Rubber Hose 22 – Engine oil filters (Full Flow) 23 – Engine oil filter (Bypass) 24 – $\varnothing 6 \times t0.7$ Steel Pipe 25 – Air cooler 26 – $\varnothing 38.1 \times t5$ Rubber Hose 27 – $\varnothing 38.1 \times t5$ Rubber Hose 28 – Lubrication Oil Pipe
(SAE J526, $\varnothing 6.3 \times t3.6$) 29 – $\varnothing 10 \times t3.5$ Rubber Hose 30 – $\varnothing 19 \times t4$ Rubber Hose 31 – Pressure Control Valve
(Marine Gear) 32 – To Lubricate Marine Gear 33 – To Marine Gear Cylinder 34 – Shift Valve 35 – Marine Gear Lubricating Oil
Cooler 36 – Trolling Valve 37 – Relief Valve (Hydraulic Oil) 38 – Hydraulic Oil Pump 39 – Marine Gear Lubricating Oil
strainer | <ul style="list-style-type: none"> 40 – Hydraulic Oil Pressure Control
Valve 41 – Turbocharger 42 – $\varnothing 38.1 \times t5$ Rubber Hose 43 – Exhaust Gas/Cooling Seawater
Mixed Outlet 44 – Mixing Elbow 45 – $\varnothing 19 \times t4$ Rubber Hose 46 – $\varnothing 38.1 \times t5$ Rubber Hose 47 – $\varnothing 38.1 \times t5$ Rubber Hose 48 – Exhaust Manifold 49 – $\varnothing 20 \times t2$ STPG370 50 – $\varnothing 19 \times t4.5$ Rubber Hose 51 – $\varnothing 20 \times t2$ STPG370 52 – Heat Exchanger 53 – Piston Cooling Oil Jet 54 – Lubrication Oil Inlet strainer 55 – $\varnothing 20 \times t2$ STPG370 56 – $\varnothing 30 \times t2.3$ STPG370 57 – Camshaft Bearing 58 – Main Bearing 59 – Injector 60 – Rocker Arm Shaft 61 – $\varnothing 44.5 \times t5$ Rubber Hose 62 – $\varnothing 38.1 \times t5$ Rubber Hose 63 – Seawater Inlet 64 – Cooling Water Pump (seawater) 65 – $\varnothing 44.5 \times t5$ Rubber Hose 66 – $\varnothing 20 \times t1.6$ STPG370 67 – $\varnothing 19 \times t4$ Rubber Hose 68 – Coolant Temperature Sensor
(option) 69 – Thermostat 70 – Hot Water Connection Outlet 71 – Cooling Water Pump (coolant) 72 – Coolant Temperature Switch 73 – Hot Water Connection Return 74 – Relief Valve
(Engine Lubricating Oil) 75 – Lubrication Oil Pump 76 – Rocker Arm Housing |
|--|---|

- | | |
|---|--|
| <ul style="list-style-type: none"> 1 – Fuel Overflow 2 – Relief Valve (Fuel Oil) 3 – Diesel Fuel Inlet 4 – $\varnothing 12$ x t1.2 STPG 5 – $\varnothing 8$ x t1 STS 6 – Fuel Pipe Mount 7 – $\varnothing 6$ x t0.7 STS 8 – Fuel Oil Block 9 – Diesel Fuel Filter 10 – $\varnothing 10$ x t1.2 STS 11 – $\varnothing 8$ x t2 STS 12 – Fuel supply pump 13 – Common rail 14 – $\varnothing 4.76$ x t0.7 Steel Pipe 15 – $\varnothing 8$ x t2 STS 16 – Lubrication Oil Pipe
(SAE J526, SAE 100R14) 17 – Pressure Control Valve
(Engine) 18 – Lubrication Oil Pipe
(SAE J526, SAE 100R14) 19 – Engine oil cooler 20 – Lubrication Oil Pipe
(SAE J526, SAE 100R14) 21 – $\varnothing 38.1$ x t5 Rubber Hose 22 – Engine oil filters (Full Flow) 23 – Engine oil filter (Bypass) 24 – $\varnothing 6$ x t0.7 Steel Pipe 25 – Air cooler 26 – $\varnothing 38.1$ x t5 Rubber Hose 27 – Lubrication Oil Pipe
(SAE J526, $\varnothing 6.3$ x t3.6) 28 – $\varnothing 38.1$ x t5 Rubber Hose 29 – $\varnothing 19$ x t4 Rubber Hose 30 – $\varnothing 10$ x t3.5 Rubber Hose 31 – Turbocharger 32 – $\varnothing 38.1$ x t5 Rubber Hose 33 – Mixing Elbow 34 – Exhaust Gas/Cooling Seawater
Mixed Outlet 35 – $\varnothing 19$ x t4 Rubber Hose 36 – $\varnothing 38.1$ x t5 Rubber Hose 37 – $\varnothing 38.1$ x t5 Rubber Hose 38 – Exhaust Manifold 39 – $\varnothing 20$ x t2 STPG370 40 – $\varnothing 19$ x t4.5 Rubber Hose 41 – $\varnothing 20$ x t2 STPG370 42 – Heat Exchanger 43 – Piston Cooling Oil Jet | <ul style="list-style-type: none"> 44 – Lubrication Oil Inlet strainer 45 – $\varnothing 20$ x t2 STPG370 46 – $\varnothing 30$ x t2.3 STPG370 47 – Camshaft Bearing 48 – Main Bearing 49 – Injector 50 – Rocker Arm Shaft 51 – $\varnothing 44.5$ x t5 Rubber Hose 52 – $\varnothing 38.1$ x t5 Rubber Hose 53 – Seawater Inlet 54 – Cooling Water Pump (seawater) 55 – $\varnothing 44.5$ x t5 Rubber Hose 56 – $\varnothing 20$ x t1.6 STPG370 57 – $\varnothing 19$ x t4 Rubber Hose 58 – Coolant Temperature Sensor
(option) 59 – Thermostat 60 – Hot Water Connection Outlet 61 – Cooling Water Pump (coolant) 62 – Hot Water Connection Return 63 – Coolant Temperature Switch 64 – Relief Valve
(Engine Lubricating Oil) 65 – Lubrication Oil Pump 66 – Rocker Arm Housing |
|---|--|

This Page Intentionally Left Blank

WIRING DIAGRAMS

Color Coding	
B	Black
R	Red
L	Blue
W	White
G	Green
Gr	Gray
Y	Yellow
Br	Brown
O	Orange
Lg	Light green
P	Pink
V	Purple

Allowable Length by Cross Sectional Area of Battery Cable	
Section of Cable mm ² (in. ²)	Allowable Length L = 1 + 2 + 3 m (ft)
40 (0.062)	< 4.5 (14.8)
60 (0.093)	< 7 (23.0)

VC10 (Vessel control system)

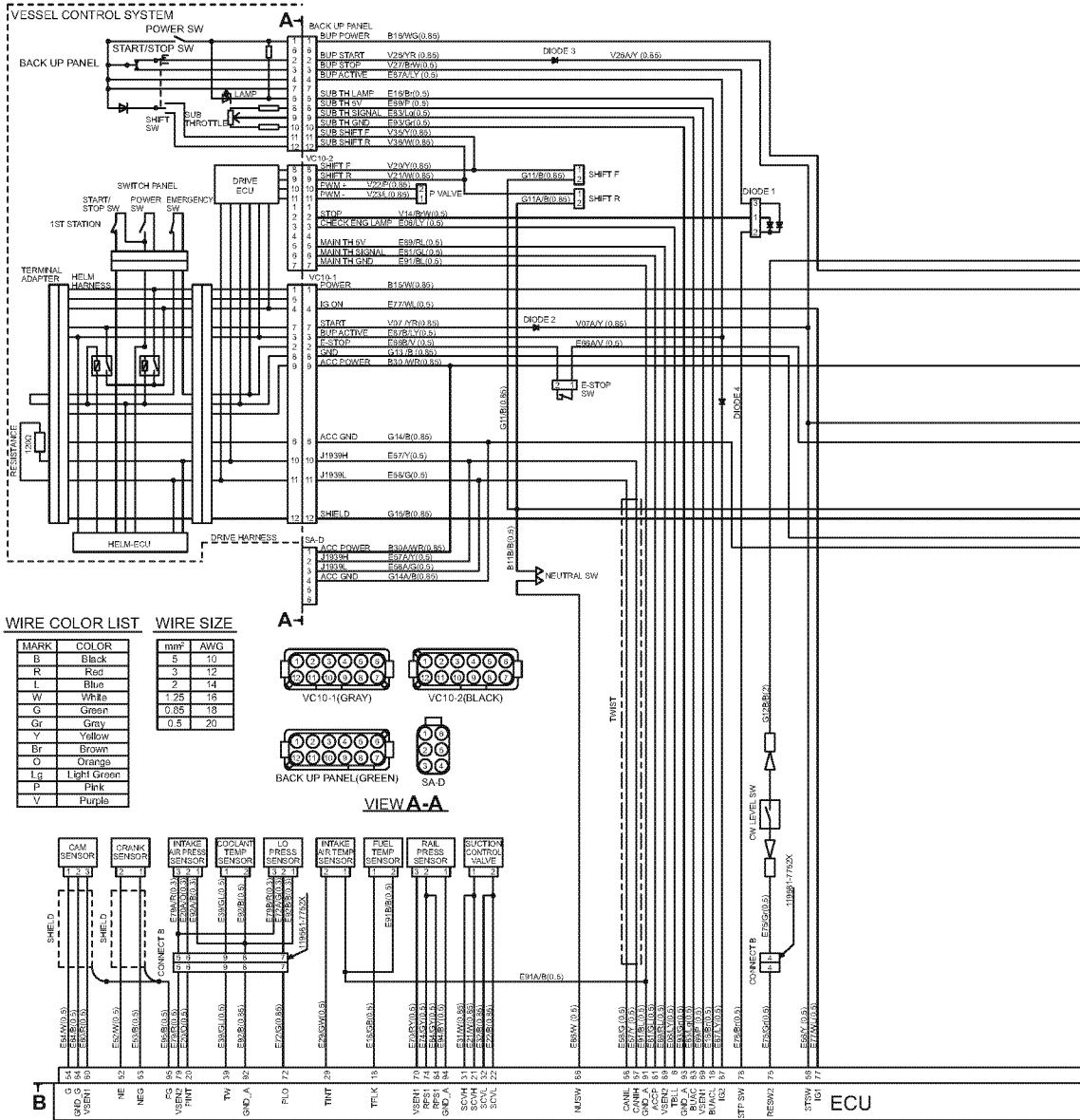

NOTE

1. EACH WIRE'S INFORMATION : [WIRE'S NAME]/[WIRE'S COLOR]/[WIRE'S SIZE(mm²)].

070865-01EN00

Figure 3

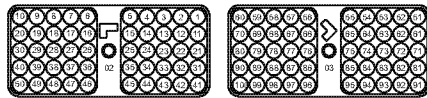
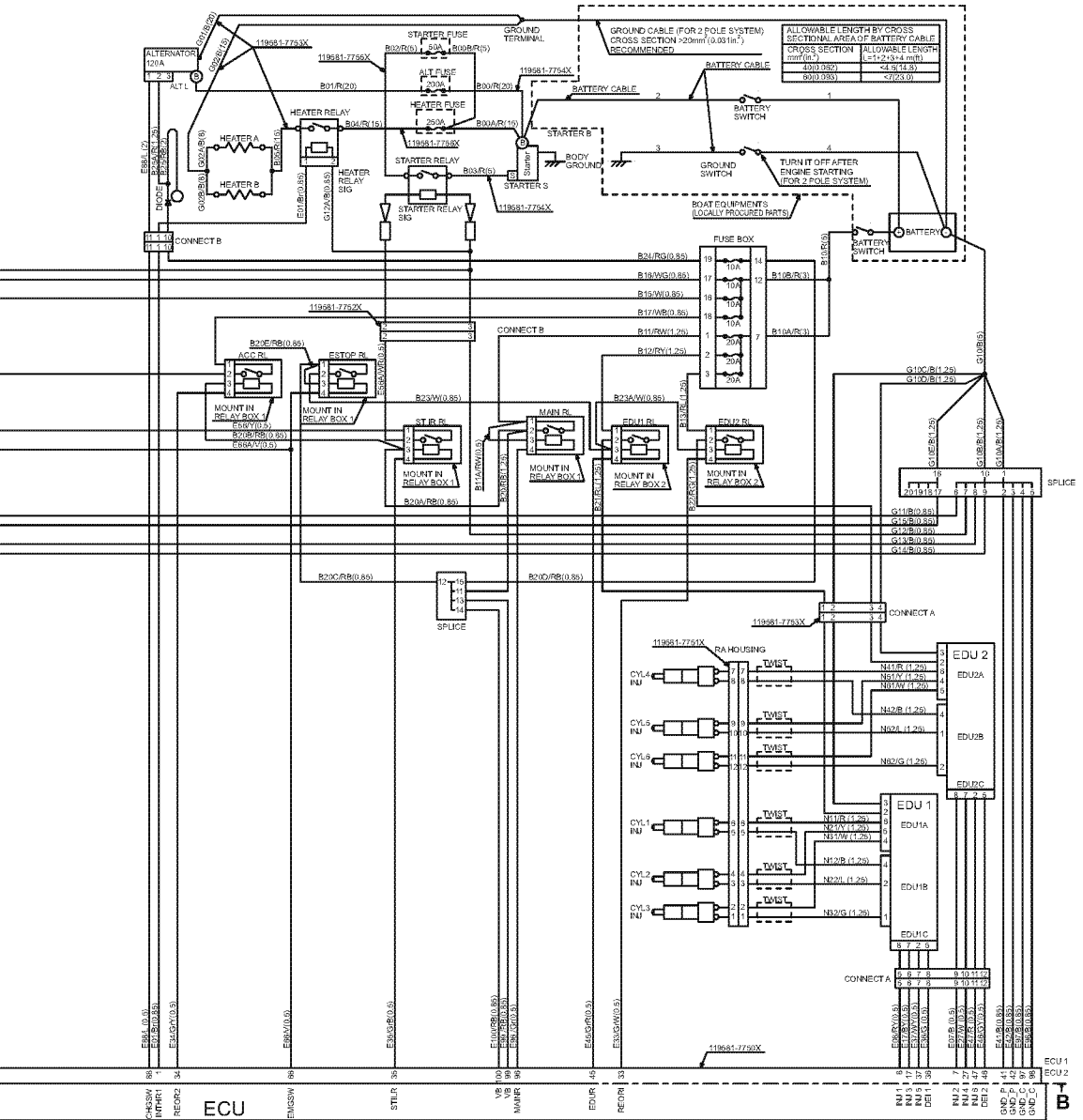

070865-02EN00

This Page Intentionally Left Blank

EPA WARRANTY USA ONLY

YANMAR CO., LTD. LIMITED EMISSION CONTROL SYSTEM WARRANTY - USA ONLY

EPA Emission control Label for 6LY440

EPA Emission control Label for 6LY400

EMISSION CONTROL INFORMATION	
THIS MARINE ENGINE COMPLIES WITH U.S. EPA REGULATIONS FOR 2018, ULTRA LOW SULFUR DIESEL FUEL ONLY.	
ENGINE FAMILY : JYDXN5.81D6C ENGINE MODEL : 6LY440	
STANDARDS NOx+HC : 5.8g/kW-hr CO : 5.0g/kW-hr PM : 0.14g/kW-hr	
APPLICATION : VARIABLE-SPEED PROPULSION ENGINES USED WITH FIXED-PITCH PROPELLERS.	
EMISSION CONTROL SYSTEM : DFI	
REFER TO OWNER'S MANUAL FOR MAINTENANCE SPECIFICATIONS AND ADJUSTMENTS.	
 YANMAR. YANMAR CO., LTD.	

119581-07610-J

Figure 1

EMISSION CONTROL INFORMATION	
THIS MARINE ENGINE COMPLIES WITH U.S. EPA REGULATIONS FOR 2018, ULTRA LOW SULFUR DIESEL FUEL ONLY.	
ENGINE FAMILY : JYDXN5.81D6C ENGINE MODEL : 6LY400	
STANDARDS NOx+HC : 5.8g/kW-hr CO : 5.0g/kW-hr PM : 0.14g/kW-hr	
APPLICATION : VARIABLE-SPEED PROPULSION ENGINES USED WITH FIXED-PITCH PROPELLERS.	
EMISSION CONTROL SYSTEM : DFI	
REFER TO OWNER'S MANUAL FOR MAINTENANCE SPECIFICATIONS AND ADJUSTMENTS.	
 YANMAR. YANMAR CO., LTD.	

119581-07620-J

Figure 2

EPA WARRANTY USA ONLY

THIS EMISSION WARRANTY APPLIES TO THE ENGINES CERTIFIED TO UNITED STATES EPA 40 CFR Part 1042 AND SOLD BY YANMAR THAT ARE INSTALLED IN VESSELS FLAGGED OR REGISTERED IN THE UNITED STATES.

Your Warranty Rights and Obligations:

Yanmar warrants to the first user and each subsequent purchaser the emission control system on your engine for periods of time listed below provided the engine has been installed according to Yanmar installation requirements and there has been no abuse, neglect, or improper maintenance of your Yanmar Marine engine.

Yanmar warrants that the engine is designed, built and tested using genuine parts and equipped so as to conform to all applicable emission requirements of the U.S. Environmental Protection Agency and is free from defects in material and workmanship which would cause this engine to fail to conform to the applicable emission regulations over its limited emission control system warranty period.

Where a warrantable emissions condition exists, Yanmar will repair your engine at no charge to you for diagnosis, parts, and labor. Warranty service or repair will be provided at authorized Yanmar Marine dealers or distributors.

It is recommended that any replacement parts used for maintenance, repair or replacement of emission control systems are Yanmar parts. The owner may elect to have maintenance, replacement or repair of the emission control components and systems performed by any repair establishment or individual and may elect to use parts other than Yanmar parts for such maintenance, replacement or repair. However, the cost of such service or parts and subsequent failures from such service or parts will not be covered under this emission control system warranty:

Warranty Period:

The warranty starts on either the date of delivery to the first end-user, or the date the unit is first leased, rented, or loaned.

The warranty period is **five (5) years** or **5000 hours** of use, whichever occurs first. In the absence of a device to measure hours of use, the engine has a warranty period of **five (5) years**.

Warranty Coverage:

Yanmar recommends that repair or replacement of any warranted parts be performed at an authorized Yanmar dealer or distributor. This limited emission control system warranty covers engine components that are a part of the emission control system of the engine as delivered by Yanmar to the original retail purchaser. Such components may include the following:

- Fuel Injection System
- Intake Manifold
- Exhaust Manifold
- Turbocharger System
- After cooler
- Electronic Engine Control Units and its associated Sensor and Actuators

Exclusions:

Failures other than those arising from defects in material and / or workmanship are not covered by this limited emissions warranty. This warranty does not extend to the following: malfunction caused by abuse, misuse, improper adjustment, modification, alteration, tampering, disconnection, improper or inadequate maintenance, improper storage or use of non-recommended fuels and lubricating oils, accident-caused damage, and replacement of expendable and / or consumable items made in connection with scheduled maintenance.

Yanmar disclaims any responsibility for incidental or consequential damages such as loss of time, inconvenience, loss of use of marine vessel / engine or commercial loss.

Owner's Responsibility:

As the Yanmar Marine engine owner, you are responsible for the performance of the required maintenance listed in your *Operation Manual*. Yanmar recommends that you retain all documentation, including receipts, covering maintenance on your marine engine, but Yanmar cannot deny warranty solely for the lack of receipts or for your failure to ensure the performance of all scheduled maintenance.

Your engine is designed to operate on diesel fuel only. Use of any other fuel may result in your engine no longer operating in compliance with applicable emission requirements. You are responsible for initiating the warranty process. You are responsible for presenting your marine engine to an authorized Yanmar dealer or distributor as soon as a problem exists.

Customer Assistance:

If you have any questions regarding your warranty rights and responsibilities or would like information on the nearest authorized Yanmar dealer or distributor, you should consult Yanmar America Corporation for assistance.

Yanmar America Corporation

Toll free telephone:

1-855-416-7091 or 1-800-872-2867

E-mail: CS_support@yanmar.com

Website: us.yanmar.com

Declaration of Conformity for Recreational Craft Propulsion Engines (inboard engines) with the requirements of Directive 2013/53/EU

(To be completed by manufacturer or, if mandated, authorised representative)

Name of engine manufacturer: Yanmar Co., Ltd.

Address: 1-32, Chayamachi, Kita-ku, Osaka

Town: _____ Post Code: 530-8311 Country: Japan

Name of Authorised Representative: Yanmar Marine International B.V.

Address: Brueplein 11

Town: Almere Post Code: 1332 BS Country: the Netherlands

Name of Notified Body for exhaust emission assessment: Société Nationale de Certification et d'Homologation

Address: 11, route de Luxembourg

Town: Sandweiler Post Code: L-5230 Country: Luxembourg ID Number: 0499

Conformity assessment module used for exhaust emissions: B+C/C1 B+D B+E B+F G H
 or engine type-approved according to: Directive 97/68/EC EC Regulation No 595/2009

Other Community Directives applied: 2014/30/EU

DESCRIPTION OF ENGINE TYPE(s)

Main Propulsion ExhaustType:

- With integral exhaust
 Without integral exhaust

Combustion Type:

- Internal combustion, Diesel (CI)
 Internal combustion, Petrol (SI)
 Other

Combustion cycle:

- 2 stroke
 4 stroke

IDENTIFICATION OF ENGINE(S) COVERED BY THIS DECLARATION OF CONFORMITY

Name of engine model or engine family:	Unique engine identification number(s) or engine family code(s)	EC Type-examination certificate or type-approval certificate number
		SNCH*2013/53*2013/53*
Engine family: RCD2-8LVX1 Engine models: 8LV370, 8LV350, 8LV320		0051*00
Engine family: RCD2-6LY44X1 Engine models: 6LY440, 6LY400		0054*00
Engine family: RCD2-4LVX1 Engine models: 4LV230, 4LV195, 4LV170, 4LV150		0104*00

This declaration of conformity is issued under the sole responsibility of the manufacturer. I declare on behalf of the manufacturer that the recreational craft propulsion engine(s) mentioned above fulfil(s) the requirements specified in Article 4 (1) and Annex I of Directive 2013/53/EU.

Name / function: Shigetaka Kawaguchi

(identification of the person empowered to sign on behalf of the engine manufacturer or his authorised representative)

Signature and title:

(or an equivalent marking)

Shigetaka Kawaguchi
 Divisional Manager
 Marine Engineering Division
 Engine Development Division
 Industrial Power Products Management Division
 Power Solution Business
 Yanmar Co., Ltd.

Date and place of issue: (yy/mm/dd) 17/08/25, Industrial Power Products Management Division, Power Solution Business, Yanmar Co., Ltd.

Essential requirements (reference to relevant articles in Annex IB & IC of the Directive)	Harmonised standards Full Application	Harmonised standards Partial application, see tech. file	Other reference documents ¹ Full Application	Other reference documents Partial Application, see tech. file	Other proof of conformity See technical. file	Specify the harmonised ² standards or other reference documents used (with year of publication like "EN ISO 8666:2002")
	<i>Tick only one box per line</i>					
Annex I.A - Design and Construction of products						
Inboard Engine (Annex I A. 5.1.1)	<input type="checkbox"/>	<input type="checkbox"/>	<input type="checkbox"/>	<input type="checkbox"/>	<input type="checkbox"/>	
Ventilation (Annex I A. 5.1.2)	<input type="checkbox"/>	<input type="checkbox"/>	<input type="checkbox"/>	<input type="checkbox"/>	<input type="checkbox"/>	
Exposed parts (Annex I A.5.1.3)	<input type="checkbox"/>	<input type="checkbox"/>	<input type="checkbox"/>	<input type="checkbox"/>	<input type="checkbox"/>	
Fuel system - General (Annex I A.5.2.1)	<input type="checkbox"/>	<input type="checkbox"/>	<input type="checkbox"/>	<input type="checkbox"/>	<input type="checkbox"/>	
Electrical System (Annex I A.5.3)	<input type="checkbox"/>	<input type="checkbox"/>	<input type="checkbox"/>	<input type="checkbox"/>	<input type="checkbox"/>	
Steering System (Annex I A.5.4)	<input type="checkbox"/>	<input type="checkbox"/>	<input type="checkbox"/>	<input type="checkbox"/>	<input type="checkbox"/>	
Fire protection - General (Annex I A.5.6.1)	<input type="checkbox"/>	<input type="checkbox"/>	<input type="checkbox"/>	<input type="checkbox"/>	<input type="checkbox"/>	
Discharge prevention (Annex I A.5.8)	<input type="checkbox"/>	<input type="checkbox"/>	<input type="checkbox"/>	<input type="checkbox"/>	<input type="checkbox"/>	
Annex I.B - Exhaust Emissions						
Propulsion Engine Identification (Annex I B.1)	<input type="checkbox"/>	<input type="checkbox"/>	<input type="checkbox"/>	<input type="checkbox"/>	<input type="checkbox"/>	
Exhaust Emission Requirements (Annex I B.2)	<input checked="" type="checkbox"/>	<input type="checkbox"/>	<input type="checkbox"/>	<input type="checkbox"/>	<input type="checkbox"/>	EN ISO 18854: 2015
Durability (Annex I B.3)	<input type="checkbox"/>	<input type="checkbox"/>	<input type="checkbox"/>	<input type="checkbox"/>	<input type="checkbox"/>	
Owner's manual (Annex I B.4)	<input type="checkbox"/>	<input type="checkbox"/>	<input type="checkbox"/>	<input type="checkbox"/>	<input type="checkbox"/>	
Annex I.C - Noise Emissions						
See Declaration of Conformity of the recreational craft in which the engine(s) has (have) been installed						

¹ Such as non-harmonised standards, rules, regulations, guidelines, etc.

² Standards published in EU Official Journal

This Page Intentionally Left Blank

YANMAR CO., LTD.

■ Large Power Products Management Division

Quality Assurance Division

5-3-1, Tsukaguchi-honmachi, Amagasaki

Hyogo, 661-0001, Japan

Phone: +81-6-6428-3137 Fax: +81-6-6421-5549

<https://www.yanmar.com/>

■ Yanmar Marine International B.V.

Brugplein 11, 1332 BS Almere-de Vaart, Netherlands

Phone: +31-36-5493534 Fax: +31-36-5493219

<http://www.yanmarmarine.com/>

Overseas Office

■ Yanmar Europe B.V. (YEU)

Brugplein 11, 1332 BS Almere-de Vaart, Netherlands

Phone: +31-36-5493200 Fax: +31-36-5493209

<http://www.yanmar.com/eu/>

■ Yanmar Asia (Singapore) Corporation Pte. Ltd. (YASC)

4 Tuas Lane, Singapore 638613

Phone: +65-6861-3855 Fax: +65-6862-5189

<https://www.yanmar.com/sg/>

■ Yanmar America Corporation (YA)

101 International Parkway,

Adairsville, GA 30103, U.S.A.

Phone: +1-770-877-9894 Fax: +1-770-877-9009

<http://www.yanmar.com/us/>

■ Yanmar Engine (Shanghai) Co., Ltd.

Room 1101-1106, No.757 Mengzi Road,

Huangpu District, Shanghai 200023 PRC

Phone: +86-21-2312-0638 Fax: +86-21-6880-8090

<https://www.yanmar.com/cn/>

As of August 1st, 2019

OPERATION MANUAL

6LY440, 6LY400

1st edition: August 2015

3rd edition: January 2017

4th edition: January 2018

4th edition 1st rev.: June 2018

4th edition 2nd rev.: October 2019

Issued by: YANMAR CO., LTD. Large Power Products Management Division

Edited by: YANMAR TECHNICAL SERVICE CO., LTD.

YANMAR

YANMAR CO., LTD.

<https://www.yanmar.com>

0ALYG-EN0013
2019.10(YTSK)