

# OPERATION MANUAL

---

MARINE ENGINES

**GM**

**1GM10**

**1GM10C**

**1GM10V**

**en** English

**YANMAR**

**California  
Proposition 65 Warning**

Diesel engine exhaust and some of its constituents are known to the state of California to cause cancer, birth defects, and other reproductive harm.

**Disclaimers:**

All information, illustrations and specifications in this manual are based on the latest information available at the time of publishing. The illustrations used in this manual are intended as representative reference views only. Moreover, because of our continuous product improvement policy, we may modify information, illustrations and/or specifications to explain and/or exemplify a product, service or maintenance improvement. We reserve the right to make any change at any time without notice. Yanmar and **YANMAR** are registered trademarks of YANMAR CO., LTD. in Japan, the United States and/or other countries.

**All Rights Reserved:**

No part of this publication may be reproduced or used in any form by any means - graphic, electronic, or mechanical, including photocopying, recording, taping, or information storage and retrieval systems - without the written permission of YANMAR CO., LTD.

Please review and comply with the applicable laws and regulations of the international export control regimes at the territory or country where the product and manual are intended to be imported and used.

OPERATION MANUAL	MODEL	1GM10, 1GM10C, 1GM10V
	CODE	0AGMM-EN0013

# TABLE OF CONTENTS

---

	Page
<b>INTRODUCTION</b> .....	1
RECORD OF OWNERSHIP .....	2
<b>SAFETY</b> .....	3
SAFETY PRECAUTIONS .....	4
General Information .....	4
Before You Operate .....	4
During Operation and Maintenance .....	4
LOCATION OF SAFETY DECALS .....	8
<b>PRODUCT OVERVIEW</b> .....	9
YANMAR GM FEATURES AND APPLICATIONS .....	9
New Engine Break-In .....	10
COMPONENT IDENTIFICATION .....	11
Service Side - 1GM10 with KM2P .....	11
Non-Service Side - 1GM10 with KM2P .....	12
LOCATION OF NAMEPLATES .....	13
MAJOR COMPONENTS AND FUNCTIONS .....	14
CONTROL EQUIPMENT .....	15
Instrument Panel (Optional) .....	15
Single-Lever Throttle and Shift Console (Optional) .....	22
<b>BEFORE YOU OPERATE</b> .....	25
INTRODUCTION .....	25
SAFETY PRECAUTIONS .....	25
DIESEL FUEL .....	26
Diesel Fuel Specifications .....	26

# TABLE OF CONTENTS

---

ENGINE OIL .....	29
Engine Oil Specifications .....	29
Engine Oil Viscosity .....	30
Checking the Engine Oil.....	30
Adding Engine Oil .....	31
MARINE GEAR OR SAIL-DRIVE OIL .....	31
Marine Gear Oil Specifications.....	31
Sail-Drive Oil Specifications - SD25.....	31
Checking Marine Gear Oil.....	32
Adding Marine Gear Oil.....	32
Checking and Adding Sail-Drive Oil .....	32
CRANKING THE ENGINE MANUALLY .....	33
CRANKING THE ENGINE ELECTRICALLY .....	34
Recheck the Engine Oil.....	34
DAILY CHECKS .....	35
Visual Checks .....	35
Checking Diesel Fuel and Engine Oil.....	35
Checking and Refilling Marine Gear Oil.....	35
Checking the Battery Electrolyte Level .....	35
Checking the Alternator Belt .....	36
Checking the Throttle and Shift Console.....	36
Checking the Warning Indicators .....	36
Preparing Fuel, Oil and Coolant in Reserve.....	36
<b>ENGINE OPERATION .....</b>	<b>37</b>
INTRODUCTION .....	37
SAFETY PRECAUTIONS.....	37
STARTING THE ENGINE ELECTRICALLY .....	39
Starting the Engine Manually .....	40
Restarting After Starting Failure.....	40
Starting at Low Temperatures.....	41
After the Engine Has Started .....	41
THROTTLE AND SHIFT LEVER OPERATION.....	42
Acceleration and Deceleration .....	42
Shifting the Engine .....	42
CAUTIONS DURING OPERATION.....	43
SHUTTING DOWN THE ENGINE .....	45
CHECKING THE ENGINE AFTER OPERATION.....	46
<b>PERIODIC MAINTENANCE .....</b>	<b>47</b>
INTRODUCTION .....	47
SAFETY PRECAUTIONS.....	47

PRECAUTIONS .....	49
The Importance of Periodic Maintenance .....	49
Performing Periodic Maintenance .....	49
The Importance of Daily Checks .....	49
Keep a Log of Engine Hours and Daily Checks .....	49
Yanmar Replacement Parts .....	49
Tools Required .....	49
Ask Your Authorized Yanmar Marine Dealer or Distributor for Help.....	49
Tightening Fasteners.....	50
PERIODIC MAINTENANCE SCHEDULE .....	51
PERIODIC MAINTENANCE PROCEDURES .....	53
After Initial 50 Hours of Operation .....	53
Every 50 Hours of Operation .....	57
Every 150 Hours of Operation .....	58
Every 250 Hours of Operation .....	59
Every 1000 Hours of Operation .....	63
<b>TROUBLESHOOTING</b> .....	65
SAFETY PRECAUTIONS .....	65
TROUBLESHOOTING AFTER STARTING .....	65
TROUBLESHOOTING INFORMATION.....	66
TROUBLESHOOTING CHART.....	67
<b>LONG-TERM STORAGE</b> .....	71
PREPARE ENGINE FOR LONG-TERM STORAGE .....	71
DRAIN SEAWATER COOLING SYSTEM .....	72
RETURNING THE ENGINE TO SERVICE .....	72
<b>SPECIFICATIONS</b> .....	73
PRINCIPAL ENGINE SPECIFICATIONS .....	73
1GM10 Engine.....	74
1GM10C Engine .....	75
1GM10V Engine .....	76
<b>SYSTEM DIAGRAMS</b> .....	77
PIPING DIAGRAMS.....	77
WIRING DIAGRAMS.....	80

**This Page Intentionally Left Blank**

# INTRODUCTION

---

Welcome to the world of Yanmar Marine! Yanmar Marine offers engines, drive systems and accessories for all types of boats, from runabouts to sailboats, and from cruisers to mega yachts. In marine leisure boating, the worldwide reputation of Yanmar Marine is second to none. We design our engines to respect nature. This means quieter engines, with minimal vibrations, cleaner than ever. All of our engines meet applicable regulations, including emissions, at the time of manufacture.

To help you enjoy your Yanmar GM series engine for many years to come, please follow these recommendations:

- Read and understand this *Operation Manual* before you operate the engine to ensure that you follow safe operating practices and maintenance procedures.
- Keep this *Operation Manual* in a convenient place for easy access.
- If this *Operation Manual* is lost or damaged, order a new one from your authorized Yanmar Marine dealer or distributor.
- Make sure this manual is transferred to subsequent owners. This manual should be considered a permanent part of the engine and remain with it.
- Constant efforts are made to improve the quality and performance of Yanmar products, so some details included in this *Operation Manual* may differ slightly from your engine. If you have any questions about these differences, please contact your authorized Yanmar Marine dealer or distributor.
- The specifications and components (instrument panel, fuel tank, etc.) described in this manual may differ from ones installed on your vessel. Please refer to the manual provided by the manufacturer of these components.
- Refer to the Yanmar Limited Warranty Handbook for a complete warranty description.

## INTRODUCTION

---

### RECORD OF OWNERSHIP

Take a few moments to record the information you need when you consult Yanmar for service, parts or documentation.

**Engine Model:** \_\_\_\_\_

**Engine Serial No.:** \_\_\_\_\_

**Date Purchased:** \_\_\_\_\_

**Dealer:** \_\_\_\_\_

**Dealer Phone:** \_\_\_\_\_



# SAFETY

---

Yanmar considers safety of great importance and recommends that anyone that comes into close contact with its products, such as those who install, operate, maintain or service Yanmar products, exercise care, common sense and comply with the safety information in this manual and on the machine's safety decals. Keep the labels from becoming dirty or torn and replace them if they are lost or damaged. Also, if you need to replace a part that has a label attached to it, make sure you order the new part and label at the same time.



This safety alert symbol appears with most safety statements. It means attention, become alert, your safety is involved! Please read and abide by the message that follows the safety alert symbol.

## DANGER

Indicates a hazardous situation which, if not avoided, *will* result in death or serious injury.

## WARNING

Indicates a hazardous situation which, if not avoided, *could* result in death or serious injury.

## CAUTION

Indicates a hazardous situation which, if not avoided, *could* result in minor or moderate injury.

## NOTICE

Indicates a situation which can cause damage to the machine, personal property and / or the environment, or cause the equipment to operate improperly.

## SAFETY PRECAUTIONS

### General Information

There is no substitute for common sense and careful practices. Improper practices or carelessness can cause burns, cuts, mutilation, asphyxiation, other bodily injury or death. This information contains general safety precautions and guidelines that must be followed to reduce risk to personal safety. Special safety precautions are listed in specific procedures. Read and understand all of the safety precautions before operation or performing repairs or maintenance.

### Before You Operate

#### DANGER

The safety messages that follow have DANGER level hazards.



Never permit anyone to install or operate the engine without proper training.

Read and understand this *Operation Manual* before you operate or service the engine to ensure that you follow safe operating practices and maintenance procedures.

- Safety signs and labels are additional reminders for safe operating and maintenance techniques.
- Consult authorized Yanmar Marine dealer or distributor for additional training.

### During Operation and Maintenance

#### WARNING

The safety messages that follow have WARNING level hazards.

#### Explosion Hazard



While the engine is running or the battery is charging, hydrogen gas is being produced and can be easily ignited. Keep the area around the battery

well-ventilated and keep sparks, open flames and any other form of ignition out of the area.

#### Fire and Explosion Hazard

Diesel fuel is flammable and explosive under certain conditions.

Never use a shop rag to catch the fuel.

Wipe up all spills immediately.

Never refuel with the engine running.

#### Fire Hazard



Undersized wiring systems can cause an electrical fire.

Store any containers containing fuel or other flammable products in a well-ventilated area, away from any combustibles or source of ignition.

Store any equipment in a designated area away from moving parts.

Never use the engine compartment for storage.

**⚠ WARNING****Sever Hazard**

Rotating parts can cause severe injury or death. Never wear jewelry, unbuttoned cuffs, ties or loose-fitting clothing and always tie long hair back when working near moving / rotating parts such as the flywheel or PTO shaft. Keep hands, feet and tools away from all moving parts.

**Alcohol and Drug Hazard**

Never operate the engine while under the influence of alcohol or drugs, or when feeling ill.

**Exposure Hazard**

Always wear personal protective equipment including appropriate clothing, gloves, work shoes, and eye and hearing protection as required by the task at hand.

**Sudden Movement Hazard**

Never operate the engine while wearing a headset to listen to music or radio because it will be difficult to hear the warning signals.

**Burn Hazard**

Some of the engine surfaces become very hot during operation and shortly after shutdown. Keep hands and other body parts away from hot engine surfaces.

**Exhaust Hazard**

Never block windows, vents or other means of ventilation if the engine is operating in an enclosed area. All internal combustion engines create carbon monoxide gas during operation and special precautions are required to avoid carbon monoxide poisoning.

## CAUTION

The safety messages that follow have CAUTION level hazards.

### **Poor Lighting Hazard**

Ensure that the work area is adequately illuminated. Always install wire cages on portable safety lamps.

---

### **Tool Hazard**

Always use tools appropriate for the task at hand and use the correct size tool for loosening or tightening machine parts.

---

### **Flying Object Hazard**

Always wear eye protection when servicing the engine or when using compressed air or high-pressure water. Dust, flying debris, compressed air, pressurized water or steam may injure your eyes.

---

### **Coolant Hazard**



Wear eye protection and rubber gloves when you handle engine coolant. If contact with the eyes or skin should occur, flush eyes and wash immediately with clean water.

## NOTICE

The safety messages that follow have NOTICE level hazards.

It is important to perform daily checks as listed in the *Operation Manual*. Periodic maintenance prevents unexpected downtime, reduces the number of accidents due to poor engine performance and helps extend the life of the engine.

---

Consult authorized Yanmar Marine dealer or distributor if you need to operate the engine at high altitudes. At high altitudes the engine will lose power, run rough and produce exhaust gases that exceed the design specifications.

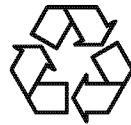

Always be environmentally responsible.

Follow the guidelines of your country's governmental agencies for the proper disposal of hazardous materials such as engine oil, diesel fuel and engine coolant. Consult the local authorities or reclamation facility.

---

Never dispose of hazardous materials by dumping them into a sewer, on the ground, or into ground water or waterways.

---

If a Yanmar Marine Engine is installed at an angle that exceeds the specifications stated in the Yanmar Marine *Installation Manuals*, engine oil may enter the combustion chamber causing excessive engine speed, white exhaust smoke and serious engine damage. This applies to engines that run continuously or those that run for short periods of time.

**NOTICE**

If you have an installation with two or three engines and only one engine is operating, the water pickup (thru-hull) of the non-running engine(s) should be closed. This will prevent water from being forced past the seawater pump and eventually finding its way into the engine. The result of water entering the engine could cause seizure or other serious problems.

If you have an installation with two or three engines, and only one engine is operating, please note that if the propeller shaft thru-hull (stuffing box) is lubricated by engine water pressure and the engines are interconnected, care must be taken that water from the running engine does not enter the exhaust of the non-running engine(s). This water could cause seizure of the non-running engine(s). Consult authorized Yanmar Marine dealer or distributor for a complete explanation of this condition.

If you have an installation with two or three engines, and only one engine is operating, it is important to limit the amount of throttle applied to the running engine. If you observe black smoke or movement of the throttle does not increase engine speed, you are overloading the engine that is running. Immediately throttle back to approximately 2/3 throttle or to a setting where the engine performs normally. Failure to do so may cause the running engine to overheat or cause excess carbon buildup which may shorten the engine's life.

Never turn off the battery switch (if equipped) or short the battery cables during operation. Damage to the electrical system will result.

## **LOCATION OF SAFETY DECALS**

Figure 1 show the location of safety decals on Yanmar GM series marine engines.

### **GM Engines**

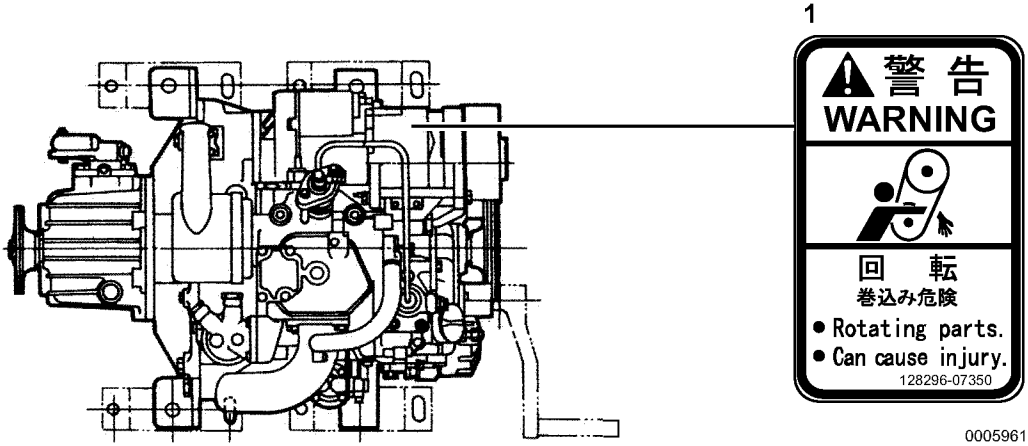

*Figure 1*

**1-Part Number: 128296-07350**

# PRODUCT OVERVIEW

---

## YANMAR GM FEATURES AND APPLICATIONS

The GM series are four-stroke swirl pre-combustion chamber diesel engines equipped with direct seawater cooling systems.

The 1GM10 is a naturally aspirated 1-cylinder engine equipped with a KM2P marine gear.

The 1GM10C is a naturally aspirated 1-cylinder engine equipped with an SD25 sail-drive.

The 1GM10V is a naturally aspirated 1-cylinder engine equipped with a KM3V marine gear.

The engines are equipped with a marine gear or sail-drive unit.

These engines are designed for pleasure craft use.

It is recommended that new vessels be propped so the engines can operate at 100 to 200  $\text{min}^{-1}$  above the Maximum Rated Power Output engine speed (3700 to 3800) to allow for some added weight and hull resistance. The engine must be able to reach the Maximum Rated Power Output (3600  $\text{min}^{-1}$ ) under full load at all times.

Failure to do so can lead to reduced vessel performance and increased smoke levels, and can cause permanent damage to your engine, which is not covered by warranty.

The engine must be installed correctly with coolant lines, exhaust gas lines and electrical wiring. Any auxiliary equipment attached to the engine should be easy to use and accessible for service. To handle the drive equipment, propulsion systems (including the propeller) and other onboard equipment, always observe the instructions and cautions given in the operation manuals supplied by the shipyard and original equipment manufacturers.

The GM series engines are designed to be operated at maximum throttle (3600  $\text{min}^{-1}$ ) for less than 5% of total engine time (30 minutes out of every 10 hours) and cruising speed (3400  $\text{min}^{-1}$  or less).

The laws of some countries may require hull and engine inspections, depending on the use, size and cruising area of the boat. The structural design, vessel application and installation of this engine all require specialized knowledge and engineering skills. See Yanmar's local subsidiary in your region or your authorized Yanmar Marine dealer or distributor.

## New Engine Break-In

As with all reciprocating engines, the way your engine is operated during its first 50 hours of operation plays a very significant role in determining how long it will last and how well the engine will perform over its lifetime.

A new Yanmar diesel engine must be operated at suitable speeds and power settings during the break-in period to allow bearing surfaces and other friction-related components, such as piston rings and valve guides, to wear in properly in order to stabilize engine lubrication and combustion.

During the break-in period, carefully observe the engine oil pressure and engine temperature.

During the first 10 hours of operation, the engine should be operated at maximum engine speed minus 400 to 500  $\text{min}^{-1}$  (approximately 60 to 70% of load) most of the time. This will ensure the sliding parts break in properly.

### NOTICE

- During this period, avoid operating at maximum engine speed and load to avoid damaging or scoring sliding parts.
  - Never operate at WOT (wide open throttle) for more than a minute at a time during the first 10 hours of operation.
- 

Do not operate the engine at low idle or at low speed and light load for more than 30 minutes at a time. Since unburned fuel and engine oil will adhere to the piston rings when operating at low speeds for long periods, this will interfere with proper movement of the rings and the diesel fuel consumption may increase. Low idle speed does not allow break-in of sliding parts.

If operating the engine at low speed and light load, you must race the engine to clean the carbon from the cylinders and the fuel injection valve.

Perform this procedure in open waters:

- With the clutch in NEUTRAL, accelerate from the low speed position to the high speed position briefly.
- Repeat this process five times.

Once past the initial 10 hours until 50 hours, the engine should be used over its full operating range, with special emphasis on running at relatively high power settings. This is not the time for an extended cruise at idle or low speed. The boat should be operated at maximum speed minus 400  $\text{min}^{-1}$  most of the time (approximately 70% load), with a 10-minute run at maximum minus 200  $\text{min}^{-1}$  (approximately 80% load) every 30 minutes and a 4 to 5 minute period of operation at WOT (wide open throttle) once every 30 minutes. During this period, be sure not to operate the engine at low speed and light load for more than 30 minutes. If operating engine at low speed and light load is necessary, race the engine after low idle operation.

To complete engine break-in, perform *After Initial 50 Hours* maintenance procedures. See *After Initial 50 Hours of Operation* on page 53.



## COMPONENT IDENTIFICATION

### Service Side - 1GM10 with KM2P

**Figure 1** and **Figure 2** illustrate a typical version of a 1GM10 engine. Your engine may have different equipment from that illustrated.

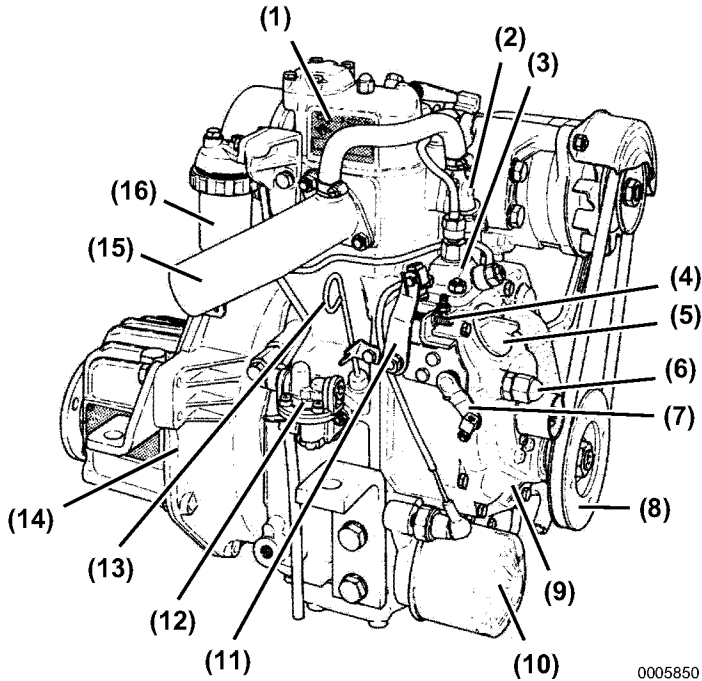
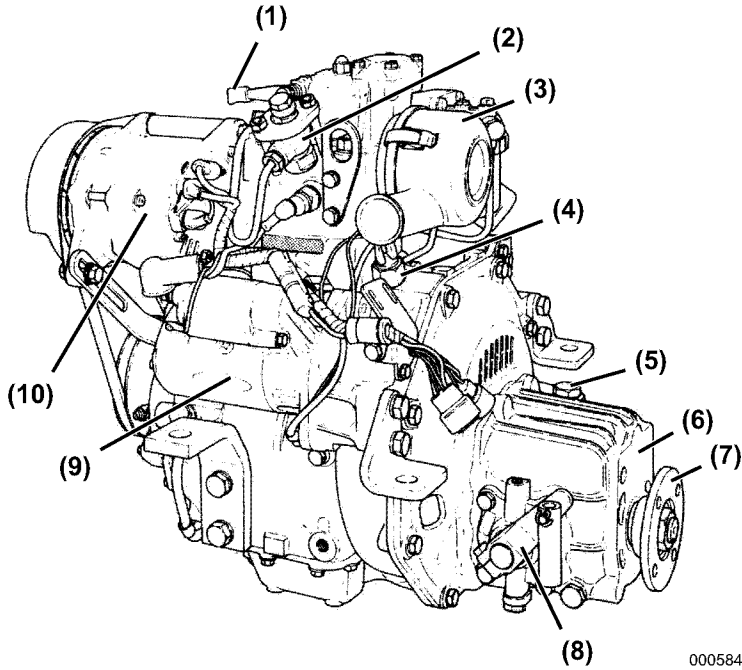

*Figure 1*

- |                            |                          |
|----------------------------|--------------------------|
| 1 – Nameplate              | 9 – Seawater Pump        |
| 2 – Thermostat Cover       | 10 – Engine Oil Filter   |
| 3 – Fuel Injection Pump    | 11 – Regulator Handle    |
| 4 – Idle Adjuster          | 12 – Fuel Feed Pump      |
| 5 – Oil Filler Cap         | 13 – Engine Oil Dipstick |
| 6 – Fuel Injection Limiter | 14 – Mounting Flange     |
| 7 – Engine Stop Lever      | 15 – Mixing Elbow        |
| 8 – Crankshaft V-Pulley    | 16 – Fuel Filter         |

## PRODUCT OVERVIEW

### Non-Service Side - 1GM10 with KM2P



0005849

*Figure 2*

- |  |                                  |
|--|----------------------------------|
| <b>1 – Decompression Lever</b>           | <b>6 – Marine Gearbox</b>        |
| <b>2 – Fuel Injection Valve</b>          | <b>7 – Output Shaft Coupling</b> |
| <b>3 – Intake Silencer (Air Cleaner)</b> | <b>8 – Shift Lever</b>           |
| <b>4 – Tachometer Sensor</b>             | <b>9 – Starter Motor</b>         |
| <b>5 – Marine Gear Dipstick</b>          | <b>10 – Alternator</b>           |

## LOCATION OF NAMEPLATES

The nameplate of the Yanmar GM series engine is shown in **Figure 3**. Check the engine's model, output, engine speed and serial number on the nameplate. Replace it if it is damaged or lost.

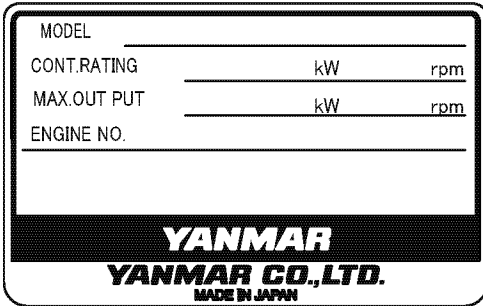

Figure 3

The engine nameplate is attached to the engine rocker arm cover.

The marine gear nameplate (**Figure 4**) is attached to the marine gear. Check the marine gear's model, gear ratio, oil used, and serial number.



177524-02903

Figure 4

The sail drive nameplate (**Figure 5**) is attached to the sail drive. Check the sail drive model and serial number.

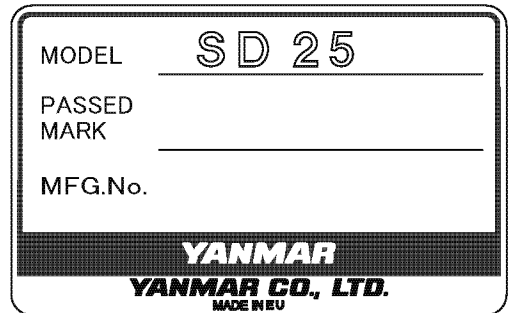

196420-12120

Figure 5

## PRODUCT OVERVIEW

### MAJOR COMPONENTS AND FUNCTIONS

Name of Component	Function
Decompression Lever	Opens the exhaust valve and releases cylinder pressure to aid in manual engine starting
Fuel Filter	Removes dirt and water from the fuel. Drain the filter periodically. The filter element (filter) should be replaced periodically.
Fuel Feed Pump (Priming Lever)	Pumps fuel from the tank to the fuel injection system. Pumping the priming lever up and down supplies fuel to the engine when the fuel system needs to be primed.
Engine Oil Filler Port	Filler port for engine oil
Marine Gear Oil Filler Port	Filler port for marine gear oil
Engine Oil Filter	Filters fine metal fragments and carbon from the engine oil. Filtered engine oil is distributed to the engine's moving parts. The filter is a spin-on type and the element should be replaced periodically. <i>See Replacing the Engine Oil Filter Element on page 55.</i>
Cooling System	Direct seawater cooling
Seawater Pump	Pumps seawater from outside the vessel and through the engine. The seawater pump has a replaceable rubber impeller.
Zinc Anode	The metal surfaces of the seawater cooling system are prone to corrosion. The zinc anode is installed in the cylinder block to prevent this. The surface of the zinc anode erodes so it needs to be replaced at fixed intervals in order to fully protect the seawater cooling system of the engine.
Intake Silencer (Air Cleaner)	The intake silencer guards against dirt entering the engine induction system and reduces the noise of air intake.
Nameplates	Nameplates are provided on the engine and the marine gear and contain the model, serial number and other data.
Starter Motor	The starter motor cranks the engine and is powered by the battery.
Alternator	The alternator is belt driven and generates electricity to charge the battery.
Engine Oil Dipstick	Gauge stick for checking the engine oil level

## CONTROL EQUIPMENT

The control equipment at the helm makes remote control operation possible. It consists of the instrument panel, which is connected to the engine by a wire harness, and the throttle and shift console, which is connected by control cables to the engine control lever and marine gear.

### Instrument Panel (Optional)

#### Equipment and Functions

The instrument panel is located at the helm and is available in two options. The following controls and indicators enable you to start, stop and monitor the condition of the engine during operation.

#### A-Type

Instrument Panel Options and Components

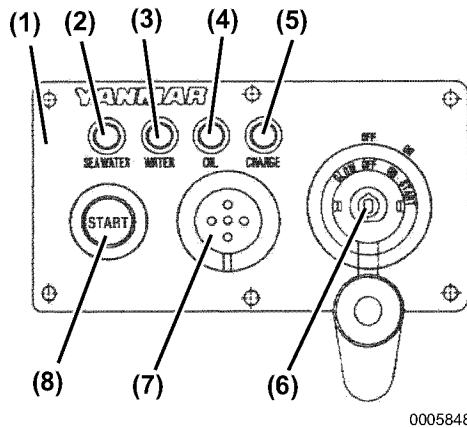

Figure 6

- 1—"A" instrument panel
- 2—Seawater in sail drive alarm lamp (Optional)
- 3—Cooling water temperature alarm Lamp
- 4—Engine oil low pressure alarm lamp
- 5—Battery low charge alarm lamp
- 6—Key switch
- 7—Alarm buzzer
- 8—Start switch (Push button)

# PRODUCT OVERVIEW

## Key Switch

When the key is in the OFF position (**Figure 7, (1)**) the electric current is off. The key can be inserted or removed in this position.

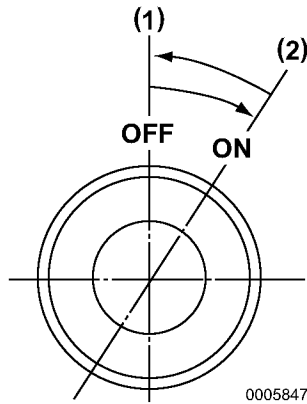

**Figure 7**

- 1–OFF Position
- 2–ON Position

The ON position (**Figure 7, (2)**) allows electrical current to the controls and equipment and allows the engine to keep running. To stop the engine, keep the key switch in the ON position and pull the engine stop knob. After stopping the engine, turn the key to the OFF position.

## Alarm

Check that indicators and alarms are working normally when the key is turned to ON.

Key Switch		OFF ⇒ ON	START ⇒ ON
Engine		Before start	Running
Alarm		Sound	No sound
Indicators	Battery Low Charge Indicator	ON	OFF
	Water Temperature Indicator	OFF	OFF
	Engine Oil Low Pressure Indicator	ON	OFF
	Water In Sail-Drive Indicator	OFF	OFF

Note: All warning indications will continue until the engine starts or the key switch is in the OFF position.

B20-Type

Instrument Panel Options and Components

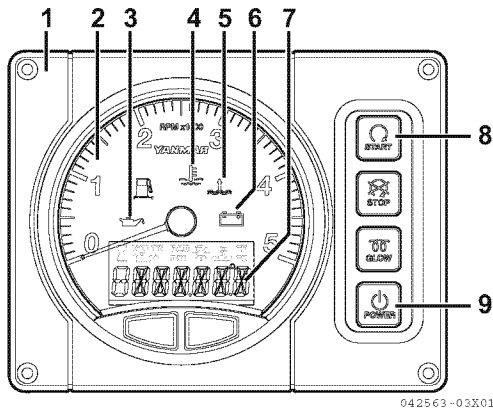

Figure 8

- 1—"B20" instrument panel
- 2-Tachometer
- 3-Engine oil low pressure alarm lamp
- 4-Cooling water temperature alarm lamp
- 5-Seawater in sail drive alarm lamp (Optional)
- 6-Battery low charge alarm lamp
- 7-LCD (Hour meter)
- 8-Start switch
- 9-Power switch

**Control panel switches**

All switches are push-buttons.

**Start switch**



042564-01X00

Pushing this switch operates the starter and starts the engine.

**Glow switch**



042566-01X00

This feature is not available on this engine.

**Stop switch**



042565-01X00

This feature is not available on this engine.

**Power switch**

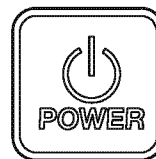

042567-01X00

Pushing this switch turns on or off the power.

## PRODUCT OVERVIEW

---

### *Indicators and Alarms (Optional)*

When a sensor detects a problem during operation, the indicator on the instrument panel will light and an alarm will sound. Indicators are located on the instrument panel and the alarms are located on the back of the panel. Under normal operating conditions, the indicators are off.



#### **Battery low charge indicator**

When the alternator output is too low, the indicator will light. When charging begins, the indicator will turn off.



#### **Cooling water temperature indicator and alarm**

When coolant temperature reaches the maximum allowable temperature (65°C [149°F] or higher), the indicator will light and the alarm will sound. Continuing operation at temperatures exceeding the maximum limit will result in damage and seizure. Check the load and troubleshoot the cooling system.



#### **Engine oil low pressure indicator and alarm**

When the engine oil pressure falls below normal, the oil pressure sensor will send a signal to the indicator, causing it to light and the alarm to sound. Stop operation to avoid damage to the engine. Check the oil level and troubleshoot the lubrication system.



#### **Water in sail drive seal indicator and alarm**

When water is detected between the seals of the sail drive, the indicator will light and the alarm will sound.



**Alarms**

**Checking the Warning Devices**

Before and after engine start, make sure that the instruments and warning devices operate correctly.

If the engine runs out of coolant or lubricating oil and the instruments and warning devices fail, they can not give you warning to prevent accidents. This can also lead to incorrect operation and cause further malfunctions of the engine.

**Before Engine Start**

1. Turn on the battery switch.
  2. Push the power switch on.
- All alarm lamps light up for 4 seconds.
  - After 4 seconds, the charge lamp and the lubricating oil pressure alarm lamp light up, and the hourmeter is displayed.
  - The alarm buzzer sounds until the engine starts.

**After Engine Start**

After engine start, make sure that the warning devices operate correctly and according to “After start” in the below table.

- All alarm lamps turn off. The above check tells you whether the electric circuit for the alarm lamps and alarm buzzer operate correctly. If they do not operate correctly, inspection and repair are required. Consult your dealer or distributor for repairs.

Correct operation of the warning devices				
Instrument panel (power switch)	Power ON			
	Immediately	After 2 seconds	After 4 seconds	
	Before start			After start
Starter switch	OFF			ON
Alarm buzzer	ON			OFF
Charge lamp	ON	ON	ON	OFF
Cooling water temperature lamp	ON	ON	OFF	OFF
Engine lubricating oil pressure lamp	ON	ON	ON	OFF
LCD display	Yanmar	Full display	Hourmeter	

**NOTICE**

When the warning devices are activated and normal operation is impossible, stop the engine and do not use it until the problem has been solved.

## PRODUCT OVERVIEW

---

### **Accessory power output**

The harness attached to the panel has a terminal where the signal that is synchronized to the panel power supply can be taken off. **(Figure 9)** (Refer to the *See Wiring Diagrams on page 80.*)

The maximum current of this output terminal is 3A. Do not use a current higher than 3A.

For the content of the output terminal, refer to the Wiring Diagrams on 82.

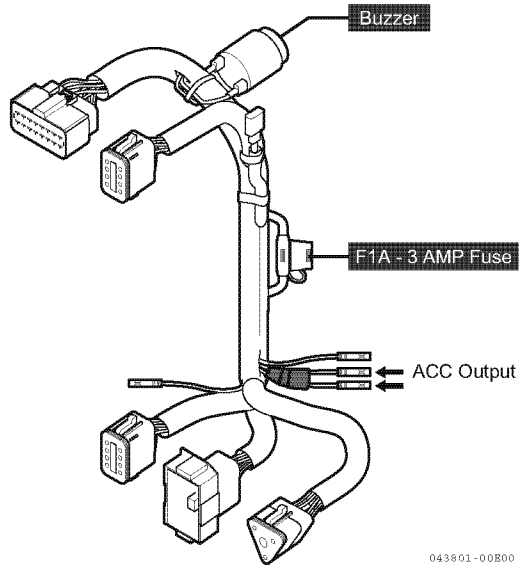

043801-00B00

**Figure 9**

## LCD control (hourmeter, coolant temperature, display brightness, oil pressure, battery voltage)

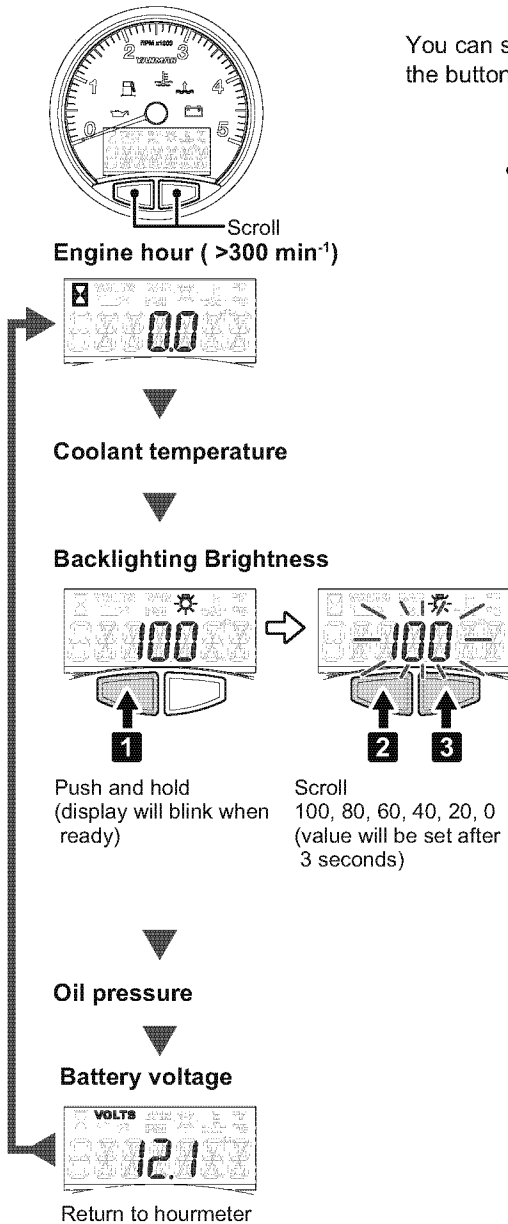

You can switch (scroll) between displays by pressing the buttons on the bottom.

- **Switching screens by pressing the right button (Pressing the left button switches the screens in the opposite direction.)**

Press the power switch.

- After 4 seconds, the LCD shows the hourmeter.

Pressing the right button on the bottom of the LCD shows the temperature display.

**This feature is not available on this engine.**

Pressing the right button again shows the LCD brightness settings.

To set the brightness of the backlight:

- 1 Press the left button continuously and the digits of the LCD start flashing.
- 2 In this condition, press the right button to decrease the brightness and the left button to increase the brightness. (The brightness changes in 6 steps of 20 %.)
- 3 To set the desired brightness, do not touch the buttons for 3 seconds.

Note: Continuously pressing means holding the button for approx. 2 seconds.

Next, press the right button to show the pressure display.

**This feature is not available on this engine.**

Press again to show the battery voltage.

Pressing the button once more returns the display to the initial hourmeter.

043716-00E01

## PRODUCT OVERVIEW

### Engine Stop Control

The engine is stopped by pulling out the engine stop knob (Figure 10, (1)). This cable is connected to the engine stop lever and cuts off the fuel supply to the engine.

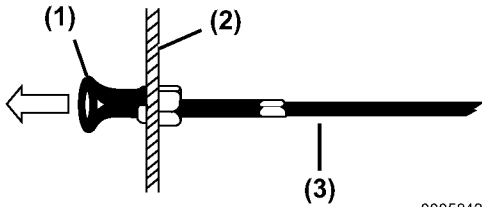

Figure 10

- 1 – Engine Stop Knob
- 2 – Bulkhead
- 3 – Engine Stop Cable

### Engine Decompression Lever

The engine decompression lever (Figure 11, (3)) releases cylinder pressure to aid in manual starting.

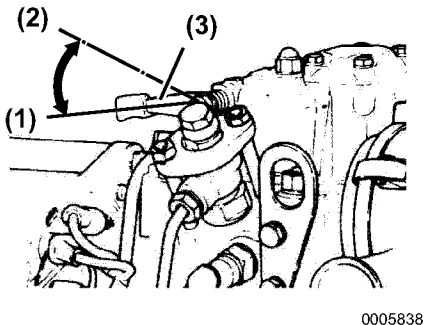

Figure 11

- 1 – RUN Position
- 2 – Decompression Position
- 3 – Decompression Lever

Raising the decompression lever to the decompression position (Figure 11, (2)) opens the exhaust valve and makes hand cranking of the engine possible. Returning the lever to its RUN position (DOWN) (Figure 11, (1)) closes the exhaust valve and normal engine operation can resume.

### Single-Lever Throttle and Shift Console (Optional)

This console (Morse Type) uses a single lever to operate the throttle and the shifting mechanism.

FORWARD (FWD) (Figure 12, (1)) - The drive shaft is engaged and the engine propels the vessel forward.

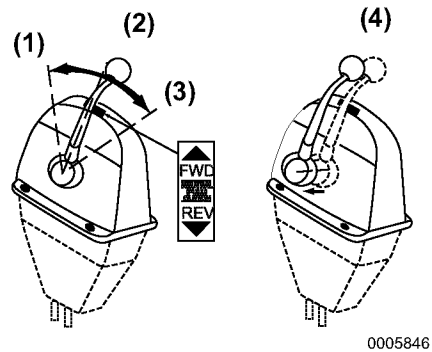

Figure 12

- 1 – FORWARD (FWD)
- 2 – NEUTRAL (N)
- 3 – REVERSE (REV)
- 4 – Pull out the lever to disengage the clutch.

NEUTRAL (N) (Figure 12, (2)) - The drive shaft is disengaged from the propeller and the engine idles.

REVERSE (REV) (Figure 12, (3)) - The drive shaft is engaged and the engine propels the vessel aft.

With the lever in the NEUTRAL position, pull the lever out from the console **(Figure 12, (4))** to disengage the clutch.

The lever controls the direction of the vessel (ahead or astern) and acts as an accelerator, increasing the engine speed as it is pushed further in the FWD or REV direction. When the lever is pulled out, engine speed can be controlled without moving the vessel. The clutch is disengaged and the vessel is in NEUTRAL (no-load position).

Note: Yanmar recommends the use of a single-lever type console for the remote control system. If only a two-lever type is available in the market, reduce engine speed to 1000 min<sup>-1</sup> or less before engaging and disengaging the marine gear clutch.

**This Page Intentionally Left Blank**

# BEFORE YOU OPERATE

---

## INTRODUCTION

This section of the *Operation Manual* describes the diesel fuel, engine oil and engine coolant specifications and how to replenish them.

## SAFETY PRECAUTIONS

Before performing any operations within this section, review the *Safety* section on page 3.

# BEFORE YOU OPERATE

## DIESEL FUEL

### Diesel Fuel Specifications

#### WARNING

**Fire and Explosion Hazard.**  
**Diesel fuel is flammable and explosive under certain conditions.**

Only use diesel fuels recommended by Yanmar for the best engine performance, to prevent engine damage. Only use clean diesel fuel.

Diesel fuel should comply with the following specifications. The table lists several worldwide specifications for diesel fuels.

DIESEL FUEL SPECIFICATION	LOCATION
ASTM D975 No. 2-D S15, No. 1-D S15	USA
EN590-2009	European Union
ISO 8217 DMX	International
BS 2869-A1 or A2	United Kingdom
JIS K2204 Grade No. 2	Japan

### Biodiesel Fuels

Yanmar approves the use of biodiesel fuels that do not exceed a blend of 7% non-mineral oil based fuel with 93% standard diesel fuel. Such biodiesel fuels are known in the marketplace as B7 biodiesel fuels. B7 biodiesel fuel can reduce particulate matter and the emission of “greenhouse” gases compared to standard diesel fuel.

If the B7 biodiesel fuel used does not meet the approved specifications, it will cause abnormal wear of injectors, reduce the life of the engine and it may affect the warranty coverage of your engine.

### ***B7 diesel fuels must meet certain specifications.***

The biodiesel fuels must meet the minimum specifications for the country in which they are used:

- In Europe, biodiesel fuels must comply with the European Standard EN590-2009, EN14214.
- In the United States, biodiesel fuels must comply with the American Standard ASTM D-6751 Grade-S15, D7467 Grade B7-S15.

Biodiesel should be purchased only from recognized and authorized diesel fuel suppliers.

### ***Precautions and concerns regarding the use of biofuels:***

- Biodiesel fuels have a higher content of methyl-esters, which may deteriorate certain metal, rubber and plastic components of the fuel system. The customer and / or boat builder are responsible to verify the usage of biodiesel compatible components on the vessel fuel supply and return systems.
- Free water in biodiesel may result in plugging of fuel filters and increased bacterial growth.
- High viscosity at low temperatures may result in fuel delivery problems, injection pump seizures and poor injection nozzle spray atomization.
- Biodiesel may have adverse effects on some elastomers (seal materials) and may result in fuel leakage and dilution of the engine lubricating oil.



- Even biodiesel fuels that comply with a suitable standard as delivered will require additional care and attention to maintain the quality of the fuel in the equipment or other fuel tanks. It is important to maintain a supply of clean, fresh fuel. Regular flushing of the fuel system, and / or fuel storage containers, may be necessary.
- The use of biodiesel fuels that do not comply with the standards as agreed to by the diesel engine manufacturers and the diesel fuel injection equipment manufacturers, or biodiesel fuels that have degraded as per the precautions and concerns above, may affect the warranty coverage of your engine.

### Additional Technical Fuel Requirements

- The fuel cetane number should be 45 or higher.
- The sulfur content must not exceed 0.5% by volume. Less than 0.05% is preferred.
- Never mix kerosene, used engine oil or residual fuels with the diesel fuel.
- Water and sediment in the fuel should not exceed 0.05% by volume.
- Keep the fuel tank and fuel-handling equipment clean at all times.
- Ash content not to exceed 0.01% by volume.
- Carbon residue content not to exceed 0.35% by volume. Less than 0.1% is preferred.
- Total aromatics content should not exceed 35% by volume. Less than 30% is preferred.
- PAH (poly cyclic aromatic hydrocarbons) content should be below 10% by volume.
- Do not use Biocide.

### Handling of Diesel Fuel

#### **⚠ WARNING**

**Fire and Explosion Hazard.**  
**Only fill the fuel tank with diesel fuel.** Filling the fuel tank with gasoline may result in a fire and will damage the engine. **Never refuel with the engine running. Wipe up all spills immediately. Keep sparks, open flames or any other form of ignition (match, cigarette, static electric source) well away when refueling.**

**Fire and Explosion Hazard.**  
**Always put the diesel fuel container on the ground when transferring the diesel fuel from the pump to the container.** Hold the hose nozzle firmly against the side of the container while filling it. **This prevents static electricity buildup which could cause sparks and ignite fuel vapors.**

1. Water and dust in the fuel may cause engine failure. When fuel is stored, be sure that the inside of the storage container is clean and dry, and that the fuel is stored away from dirt or rain.

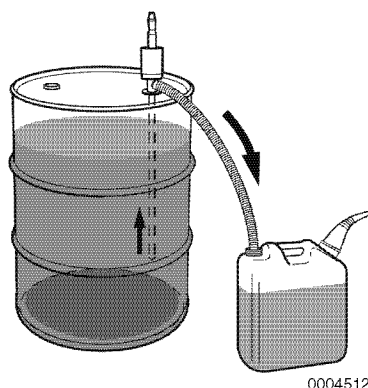

**Figure 1**

## BEFORE YOU OPERATE

2. Keep the fuel container stationary for several hours to allow any dirt or water to settle to the bottom of the container. Use a pump to extract the clear, filtered fuel from the top of the container.

### Fuel Tank (Optional)

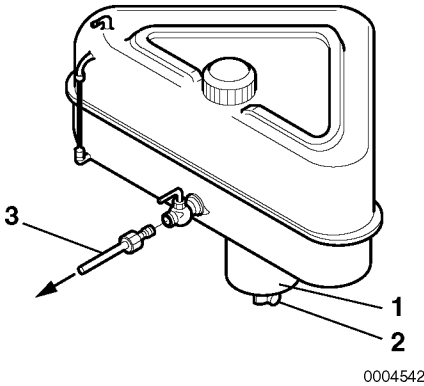

Figure 2

- 1 – Sediment Bowl
- 2 – Drain Cock
- 3 – Fuel Line to Engine

Install a drain cock (**Figure 2, (2)**) at the bottom of the fuel tank to remove water and contaminants from the sediment bowl (**Figure 2, (1)**).

The fuel outlet should be positioned 20 to 30 mm (0.75 to 1.125 in.) above the bottom of the tank so that only clean fuel is distributed to the engine.

### Fuel System

Install the fuel line from the fuel tank to the fuel injection pump as shown in **Figure 3**. The recommended fuel / water separator (**Figure 3, (3)**) (optional) is installed at the center section of that line.

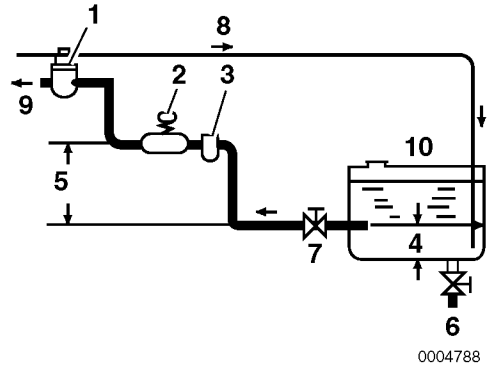

Figure 3

- 1 – Fuel Filter
- 2 – Fuel Feed Pump (Priming Lever)
- 3 – Fuel / Water Separator (Optional)
- 4 – Approximately 20 - 30 mm (0.75 - 1.125 in.)
- 5 – Within 500 mm (20 in.)
- 6 – Drain Cock
- 7 – Fuel Cock
- 8 – Fuel Return Line
- 9 – To Fuel Injection Pump
- 10 – Fuel Tank

### Filling the Fuel Tank

Before filling fuel tank for the first time:

#### **WARNING**

**Fire and Explosion Hazard.**  
**Never refuel with the engine running.**

Rinse fuel tank with kerosene or diesel fuel. Dispose of waste properly.

To fill the fuel tank:

**⚠ WARNING**

**Fire and Explosion Hazard.**  
Operate bilge ventilation (blowers) for a minimum of 5 minutes to purge fumes from engine compartment after refueling. Never operate bilge blower while refueling. Doing so can pump explosive fumes into the engine compartment and result in an explosion.

1. Clean the area around the fuel cap.
2. Remove the fuel cap from the fuel tank.
3. Fill the tank with clean fuel free of oil and dirt.

**⚠ WARNING**

**Fire and Explosion Hazard.**  
Hold the hose nozzle firmly against the filler port while filling. This prevents static electricity buildup which could cause sparks and ignite fuel vapors.

4. Stop fueling when the gauge shows the fuel tank is full.

**⚠ WARNING**

**Fire and Explosion Hazard.**  
Never overfill the fuel tank.

5. Replace the fuel cap and hand-tighten. Over-tightening the fuel cap will damage it.

**ENGINE OIL****Engine Oil Specifications****NOTICE**

Only use the engine oil specified. Other engine oils may affect warranty coverage, cause internal engine components to seize and / or shorten engine life. Never mix different types of engine oil. This may adversely affect the lubricating properties of the engine oil.

Use an engine oil that meets or exceeds the following guidelines and classifications:

- API Service Categories: CC or higher  
TBN value: 9 or more

The oil must be changed when the Total Base Number (TBN) has been reduced to 2.0.

TBN (mgKOH/g) test method: JIS K-2501-5.2-2(HCl), ASTM D4739(HCl)

- Recommended SAE Viscosity: 10W30, 15W40. Engine oil 10W30 and 15W40 can be used throughout the year.
- Never use API Service Category CG-4 or CH-4 oils.

**NOTICE**

- Be sure the engine oil, engine oil storage containers and engine oil filling equipment are free of sediment or water.
- Change the engine oil after the first 50 hours of operation and then at every 150 hours thereafter. *See Changing the Engine Oil on page 54.*

# BEFORE YOU OPERATE

## NOTICE

- Select the oil viscosity based on the ambient temperature where the engine is being operated. See the SAE Service Grade Viscosity Chart (**Figure 4**).
- Yanmar does not recommend the use of engine oil “additives.”

## Handling Engine Oil

1. When handling and storing engine oil, be careful not to allow dust and water to contaminate the oil. Clean around the filler port before filling.
2. Do not mix oils of different types or brands. Mixing may cause the chemical characteristics of the oil to change and lubricating performance to decrease, reducing the engine’s life.
3. Engine oil should be replaced at the specified intervals, regardless of the engine’s operation history. See *Periodic Maintenance Schedule* on page 51.

## Engine Oil Viscosity

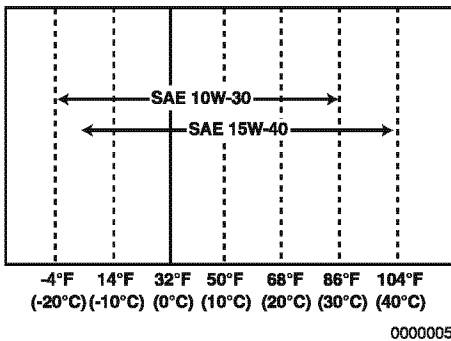

Figure 4

Select the appropriate engine oil viscosity based on the ambient temperature shown in the SAE Service Grade Viscosity Chart in **Figure 4**.

## NOTICE

If you intend to operate your equipment at temperatures outside the limits shown, you must consult your authorized Yanmar Marine dealer or distributor for special lubricants or starting aids.

## Checking the Engine Oil

1. Make sure the engine is off. It is recommended that the engine be as level as possible before checking the oil.
2. Remove the dipstick (**Figure 5, (2)**) and wipe with a clean cloth.

## NOTICE

Prevent dirt and debris from contaminating the engine oil. Carefully clean the dipstick and the surrounding area before you remove the cap.

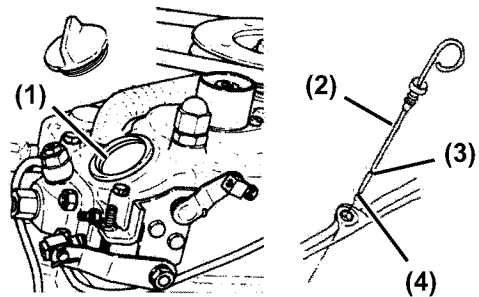

Figure 5

- 1 – Filler Port
- 2 – Dipstick
- 3 – Upper Limit
- 4 – Lower Limit

3. Fully reinsert the dipstick.
4. Remove the dipstick. The oil level should be between the upper **(Figure 5, (3))** and lower **(Figure 5, (4))** lines on the dipstick.
5. Add oil if necessary. *See Adding Engine Oil on page 31.*
6. Fully reinsert the dipstick.

## Adding Engine Oil

### NOTICE

Prevent dirt and debris from contaminating the engine oil. Carefully clean the dipstick and the surrounding area before you remove the cap.

1. Remove the yellow oil filler port cap from filler port **(Figure 5, (1))** on the rocker arm cover and fill with engine oil.
2. Fill with engine oil to the upper limit **(Figure 5, (3))** on the dipstick **(Figure 5, (2))**.

### NOTICE

Never overfill the engine with engine oil.

Engine Oil Capacity	
1GM10 (V) (C)	Full: 1.5 L (1.6 qt)

3. Insert the dipstick fully to check the level.

### NOTICE

Always keep the oil level between upper and lower lines on the oil cap / dipstick.

4. Hand-tighten the filler port cap securely.

## MARINE GEAR OR SAIL-DRIVE OIL

### Marine Gear Oil Specifications

Use marine gear oil that meets or exceeds the following guidelines and classifications:

#### KM2P-1 (S), (G) or (GG):

- API Service Categories: CD or higher
- SAE Viscosity: #20 or #30

### Sail-Drive Oil Specifications - SD25

Refer to the *Sail-Drive Operation Manual* for the procedure to fill or replace the drive oil.

#### SD25:

- API Service Category: CC or higher
- SAE Viscosity: 10W-30

# BEFORE YOU OPERATE

## Checking Marine Gear Oil

1. Turn the engine off. Make sure the engine is as level as possible and wipe area clean around the marine gear filler port (**Figure 6, (2)**).

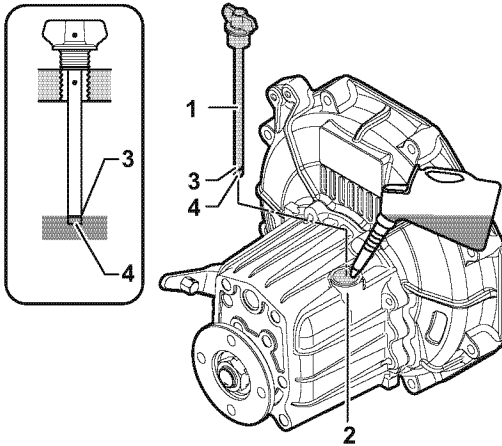

**Figure 6**

- 1 – Dipstick  
(Filler cap combined type)
- 2 – Marine Gear Filler Port
- 3 – Upper Limit
- 4 – Lower Limit (Dipstick end)

Marine Gear Oil Capacity	
KM2P	0.3 L (0.32 qt)

2. Remove the filler cap at the top of the housing.
3. Remove the dipstick (**Figure 6, (1)**) and wipe with a clean cloth.
4. Re- insert the dipstick without screw in, please see illustration (**Figure 6**).
5. Remove the dipstick. The oil level should be between the upper (**Figure 6, (3)**) and lower (**Figure 6, (4)**) lines on the dipstick.
6. Screw in the dipstick.

## Adding Marine Gear Oil

1. Make sure the engine is as level as possible.
2. Remove the filler cap / dipstick (**Figure 6, (1)**) at the top of the housing.
3. Fill with oil to the upper limit on the dipstick (**Figure 6, (3)**).

### NOTICE

Never overfill the marine gear with oil.

4. Screw in the dipstick.
5. Hand-tighten the filler port cap.

## Checking and Adding Sail-Drive Oil

Refer to the *Sail-Drive Operation Manual* for the procedure for checking and filling the sail-drive oil.

## CRANKING THE ENGINE MANUALLY

### NOTICE

When performing engine break-in or if the engine has not been used for a long period of time, engine oil will not be distributed to all the operating parts. Using the engine in this condition will lead to seizure.

After a long period of non-use, distribute engine oil to each part by cranking the engine. Perform the following procedure before beginning operation:

1. Open the seacock.
2. Open the fuel cock.
3. Put the remote control shift lever in the NEUTRAL position.
4. Raise the decompression lever (Figure 7, (3)) up.

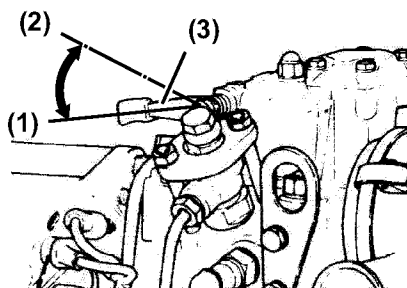

0005838

**Figure 7**

- 1 – RUN Position
- 2 – Decompression Position
- 3 – Decompression Lever

5. Slide the starter handle (Figure 8, (1)) on the starter shaft (Figure 8, (1)), align the groove and pin, and turn the engine over about 10 times.

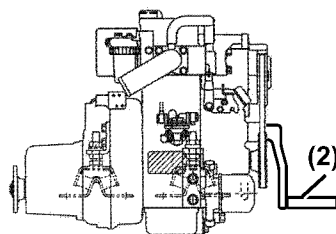
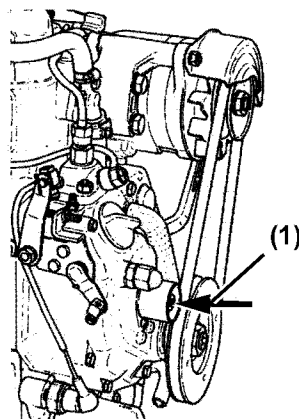

0005888

**Figure 8**

- 1 – Starter Shaft
- 2 – Starter Handle

6. Listen for any abnormal noises while cranking the engine.
7. Remove the starter handle.
8. Place the decompression lever in the RUN position.

### CRANKING THE ENGINE ELECTRICALLY

#### NOTICE

When performing engine break-in or if the engine has not been used for a long period of time, engine oil will not be distributed to all of the operating parts. Using the engine in this condition will lead to seizure.

After a long period of non-use, distribute engine oil to each part by cranking the engine. Perform the following procedure before beginning operation:

1. Open the seacock.
2. Open the fuel cock.

Note: If the engine has not been operated for a long period of time, check that the key can be moved from the OFF to the ON position smoothly.

3. Put the remote control shift lever in the NEUTRAL position.
4. Pull the engine stop knob **(Figure 9, (1))** out and hold continuously while cranking.

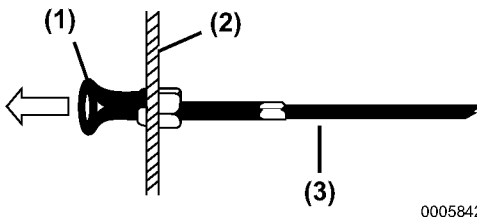

**Figure 9**

- 1 – Engine Stop Knob
- 2 – Bulkhead
- 3 – Engine Stop Cable

5. With the key in the ON position, push the start button and the engine will begin cranking.
6. Continue cranking for about 5 seconds and listen for any unusual noises.

#### NOTICE

If the engine stop knob is released (pushed in) during the cranking procedure, the engine will start. Never start the engine in this mode.

### Recheck the Engine Oil

When the oil is distributed throughout the internal components, start the engine and run at no load for about 5 minutes. This will ensure that all oil galleys, oil filters and oil tubes are full of oil. Shut the engine down and recheck the engine oil level. See *Checking the Engine Oil on page 30*. Add oil to the proper level, if necessary.



## DAILY CHECKS

Before starting for the day, make sure the Yanmar engine is in good operating condition.

### CAUTION

**It is important to perform daily checks as listed in this Operation Manual. Periodic maintenance prevents unexpected downtime, reduces the number of accidents due to poor engine performance and helps extend the life of the engine.**

Make sure you check the following items:

### Visual Checks

1. Check for engine oil leaks.
2. Check for fuel leaks.

### WARNING

**Avoid skin contact with the high-pressure diesel fuel spray caused by a fuel system leak, such as a broken fuel injection line. High-pressure fuel can penetrate your skin and result in serious injury. If you are exposed to high-pressure fuel spray, obtain prompt medical treatment. Never check for a fuel leak with your hands. Always use a piece of wood or cardboard. Have your authorized Yanmar Marine dealer or distributor repair the damage.**

3. Check for engine seawater leaks.
4. Check for damaged or missing parts.
5. Check for loose, missing or damaged fasteners.

6. Check the electrical harnesses for cracks, abrasions, and damaged or corroded connectors.
7. Check hoses for cracks, abrasions, and damaged, loose or corroded clamps.
8. Check the fuel filter / water separator for water and contaminants. If you find any water or contaminants, drain the fuel filter / water separator. See *Draining the Fuel Filter / Water Separator on page 54*. If you have to drain the fuel filter / water separator frequently, drain the fuel tank and check for water in your fuel supply. See *Draining the Fuel Tank on page 53*.

### CAUTION

**If any problem is noted during the visual check, the necessary corrective action should be taken before you operate the engine.**

### Checking Diesel Fuel and Engine Oil

Follow the procedures in *Filling the Fuel Tank on page 28* and *Checking the Engine Oil on page 30* to check these levels.

### Checking and Refilling Marine Gear Oil

*Checking Marine Gear Oil on page 32*.

### Checking the Battery Electrolyte Level

Check the battery electrolyte level before use. See *Inspecting the Battery Electrolyte Level (Serviceable Batteries Only) on page 58*.

### **Checking the Alternator Belt**

Check the belt tension before use. See *Checking and Adjusting the Alternator V-Belt Tension* on page 56.

### **Checking the Throttle and Shift Console**

Check the operation of the throttle and shift control lever. Make sure it moves smoothly. If it is hard to operate, grease the joints of the control cable and lever bearings. If the lever has excessive play, adjust the control cable connectors and clamps. See *Inspecting and Adjusting the Throttle and Shift Control Cables* on page 56.

### **Checking the Warning Indicators**

Check to ensure the engine instruments and warning indicators are functioning properly. See *Alarms* on page 19. Check them often during operation.

### **Preparing Fuel, Oil and Coolant in Reserve**

Prepare sufficient diesel fuel for the day's operation. Always store engine oil and coolant in reserve (for at least one refill) onboard, to be ready for emergencies.

# ENGINE OPERATION

---

## INTRODUCTION

This section of the *Operation Manual* describes the diesel fuel, engine oil and engine coolant specifications and how to replenish them. It also describes the daily engine checkout.

## SAFETY PRECAUTIONS

Before performing any operations within this section, review the *Safety* section on page 3.

### WARNING

#### **Fire and Explosion Hazard**



Never jump-start the engine. Sparks caused by shorting the battery to the starter terminals may cause a fire or explosion. **ONLY** use the start switch on the instrument panel to start the engine.

---

#### **Sudden Movement Hazard**

Be sure the boat is in open water away from other boats, docks or other obstructions before increasing engine speed. Avoid unexpected equipment movement. Shift the marine gear into the NEUTRAL position any time the engine is at idle.

---

## **⚠ WARNING**

To prevent accidental equipment movement, never start the engine in gear.

### **Sever Hazard**



Keep children and pets away while the engine is operating.

## **NOTICE**

If any indicator illuminates during engine operation, stop the engine immediately. Determine the cause and repair the problem before you continue to operate the engine.

If the alarm indicator with audible alarm fails to display and go out about 3 seconds after the ignition switch is turned on, consult authorized Yanmar Marine dealer or distributor for service before operating the engine

If the vessel is equipped with a water lift (water lock) muffler, excessive cranking could cause seawater to enter the cylinders and damage the engine. If the engine does not start after cranking for 10 seconds, close the thru-hull water intake valve to avoid filling the muffler with water. Crank for 10 seconds at a time until the engine starts. When the engine does start, stop the engine immediately and turn off the switch.

Be sure to re-open the seacock and restart the engine. Operate the engine normally.

---

## **NOTICE**

Observe the following environmental operating conditions to maintain engine performance and avoid premature engine wear:

- Avoid operating in extremely dusty conditions.
- Avoid operating in the presence of chemical gases or fumes.
- Never run the engine if the ambient temperature is above +40°C (+104°F) or below -16°C (+5°F).
- If the ambient temperature exceeds +40°C (+104°F), the engine may overheat and cause the engine oil to break down.
- If the ambient temperature is below -16°C (+5°F), rubber components such as gaskets and seals will harden causing premature engine wear and damage.
- Contact your authorized Yanmar Marine engine dealer or distributor if the engine will be operated outside of this standard temperature range.

Never engage the starter motor while the engine is running. Damage to the starter motor pinion and / or ring gear will result.

---

# STARTING THE ENGINE ELECTRICALLY

## NOTICE

If the vessel is equipped with a water lift (water lock) muffler, excessive cranking could cause seawater to enter the cylinders and damage the engine. If the engine does not start after cranking for 10 seconds, close the thru-hull water intake valve to avoid filling the muffler with water. Crank for 10 seconds or until the engine starts. When the engine does start, stop the engine immediately and turn the switch to the OFF position.

1. Open the seacock (if equipped).
2. Open the fuel cock.
3. Put the remote control shift lever in the NEUTRAL position (**Figure 1, (1)**).

Note: Safety equipment should make it impossible to start the engine in any position other than NEUTRAL.

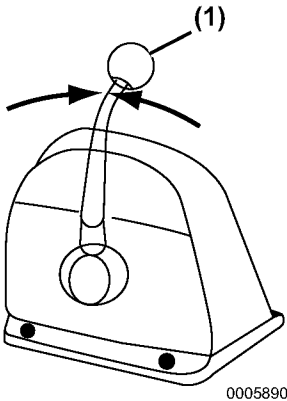

Figure 1

1 – NEUTRAL (N)

4. Turn the master battery switch (if equipped) to ON.
5. Turn the key switch to the ON position (**Figure 2, (2)**). Ensure that the instrument panel indicators light and the alarm sounds. This indicates that the indicators and the alarm are working correctly.

Note: The water temperature alarm indicator and water in Sail-Drive indicator should not come on during start-up.

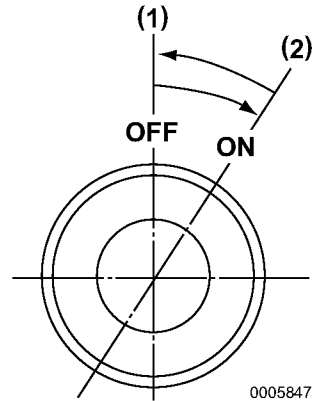

Figure 2

1 – OFF position  
2 – ON position

6. Push the start button. Release the start button when the engine has started.

## NOTICE

Never hold the start button for longer than 15 seconds or the starter motor will overheat.

7. The alarm should stop and the indicator lamps should go out.

## NOTICE

If any indicator fails to illuminate when the key switch is in the ON position, consult authorized Yanmar Marine dealer or distributor for service before operating the engine.

### Starting the Engine Manually

1. Open the seacock (if equipped).
2. Open the fuel cock.
3. Put the remote control shift lever in the NEUTRAL position (**Figure 3, (1)**).

Note: Safety equipment should make it impossible to start the engine in any position other than NEUTRAL.

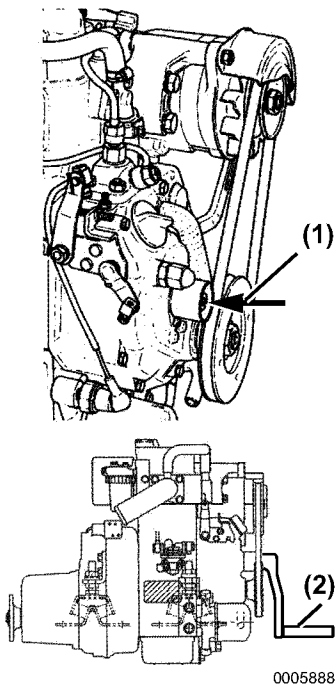

**Figure 3**

- 1 – Starting Shaft**
- 2 – Starting Handle**

4. Turn the master battery switch (if equipped) to ON.
5. Raise the decompression lever up. See *Cranking the Engine Manually* on page 33.
6. Slide the starter handle (**Figure 3, (2)**) on the starter shaft (**Figure 3, (1)**), align the groove and pin, and turn by hand.
7. Turn the handle vigorously. When engine rotation is rapid, return the decompression handle to the RUN position.
8. Remove the starter handle from the starter shaft after the engine starts.

### Restarting After Starting Failure

Before pushing the start button again, be sure the engine has stopped completely. Never attempt to restart the engine while the engine is running. The pinion gear on the starter motor will be damaged.

## NOTICE

- Never hold the start button for longer than 15 seconds or the starter motor will overheat.
- Never attempt to restart the engine if the engine has not stopped completely. Pinion gear and starter motor damage will occur.

## Air Bleeding from the Fuel System After Starting Failure

If the engine does not start after several attempts, there may be air in the fuel system. If air is in the fuel system, fuel cannot reach the fuel injection pump. Bleed the air from the fuel system according to the following steps:

1. Check the fuel tank level.
2. Loosen the air vent bolt at the top of the fuel / water separator. When fuel is free of bubbles, retighten the air vent bolt.
3. Loosen the air vent bolts of the fuel filter and fuel injection pump.
4. Pump fuel with the fuel feed pump by moving the lever on the left side of the fuel feed pump up and down.
5. Allow the fuel containing air bubbles to flow out of the air vent bolt holes.
6. When the fuel no longer contains air bubbles, tighten the air vent bolts.
7. Try starting the engine again.

## Starting at Low Temperatures

Comply with local environmental requirements. Do not use starting aids. Using a starting aid may void the warranty.

### NOTICE

Never use an engine starting aid such as ether. Engine damage will result.

To limit white smoke, run the engine at low speed and under moderate load until the engine reaches normal operating temperature. A light load on a cold engine provides better combustion and faster engine warm-up than no-load.

Avoid running the engine at idling speed any longer than necessary.

## After the Engine Has Started

After the engine has started, check the following items at a low engine speed.

1. Check that the gauges, indicators and alarm are normal.
2. Check for any water, fuel or engine oil leaks. If any leaks are found, shut down the engine and perform the necessary repairs.

### WARNING

**Never check for a fuel leak with your hands. Always use a piece of wood or cardboard. Have your authorized Yanmar Marine dealer or distributor repair the damage. Avoid skin contact with the high-pressure diesel fuel spray caused by a fuel system leak such as a broken fuel injection line. High-pressure fuel can penetrate your skin and result in serious injury. If you are exposed to high-pressure fuel spray, obtain prompt medical treatment.**

3. Check that the smoke color, engine vibration and sound are normal.
4. When there are no problems, keep the engine at low speed with the boat still stopped to distribute engine oil to all parts of the engine.
5. Check that water is being discharged from the seawater outlet pipe. Operation with inadequate seawater discharge will damage the impeller of the seawater pump. If seawater discharge is too low, stop the engine immediately. Identify the cause and repair.

## NOTICE

The engine will seize if it is operated when cooling seawater discharge is inadequate or if load is applied without any warm-up operation.

- Is the seacock open?
- Is the inlet of the seacock on the hull bottom clogged?
- Is the seawater suction hose broken or does the hose suck air because of a loose clamp?

When operating the engine at low speed for long periods of time, race the engine once every two hours. Race the engine with the clutch in NEUTRAL, accelerate from the low speed position to the high speed position and repeat this process about five times. This cleans out carbon from the cylinders and the fuel injection valves.

## NOTICE

Neglecting to race the engine will result in poor smoke color and reduce engine performance.

Periodically operate the engine near maximum speed while underway. This will generate higher exhaust temperatures, which will help clean out hard carbon deposits, maintain engine performance and prolong the life of the engine.

For troubleshooting assistance, see *Troubleshooting After Starting on page 65* or *Troubleshooting Chart on page 67*.

If necessary, consult authorized Yanmar Marine dealer or distributor.

## THROTTLE AND SHIFT LEVER OPERATION

### Acceleration and Deceleration

Note: Direction of travel will vary depending on installation location.

Use the throttle handle to control acceleration and deceleration. Move the handle slowly.

### Shifting the Engine

## NOTICE

Shifting the marine gear while operating at high speed or not pushing the handle fully into position (partial engagement) will result in damage to marine gear parts and abnormal wear.

1. Before using the marine gear, be sure to move the throttle handle to a low idle position (less than 1000 rpm). Move the throttle handle slowly to a higher speed position after completing clutch engagement.

## NOTICE

Never shift the marine gear at high engine speed. During normal operation, the marine gear should only be shifted with the engine at idle.

2. When moving the handle between FORWARD (**Figure 4, (1)**) and REVERSE (**Figure 4, (3)**), bring the clutch to NEUTRAL (**Figure 4, (2)**) and pause before slowly shifting to the desired position. Do not shift abruptly from FORWARD to REVERSE or vice versa.



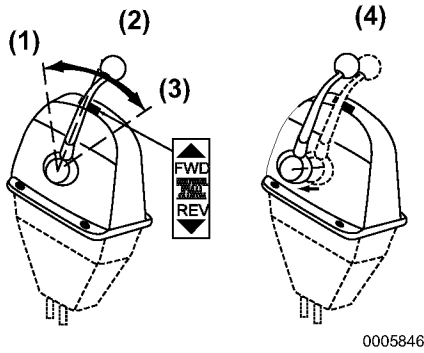

**Figure 4**

- 1 – FORWARD (FWD)**
- 2 – NEUTRAL (N)**
- 3 – REVERSE (REV)**
- 4 – Pull the lever to disengage the clutch.**

## CAUTIONS DURING OPERATION

### NOTICE

Engine trouble can arise if the engine is operated for a long time under overloaded conditions with the control handle in the full throttle position (maximum engine speed position), exceeding the continuous rated output engine speed. Operate the engine at about 100 min<sup>-1</sup> lower than the full throttle engine speed.

Note: If the engine is in the first 50 hours of operation, see *New Engine Break-In* on page 10 .

Always be on the lookout for problems during engine operation.

Pay particular attention to the following:

- Is sufficient seawater being discharged from the exhaust and seawater outlet pipe?

If the discharge is small, stop the engine immediately; identify the cause and repair.

- Is the smoke color normal?

The continuous emission of black exhaust smoke indicates engine overloading. This shortens the engines life and should be avoided.

- Are there abnormal vibrations or noise?

### NOTICE

Excessive vibration may cause damage to the engine, marine gear, hull and onboard equipment. In addition, it causes able passenger and crew discomfort.

---

Depending on the hull structure, engine and hull resonance may suddenly become great at a certain engine speed range, causing heavy vibrations. Avoid operation in this speed range. If you hear any abnormal sounds, stop the engine and inspect.

- Alarm buzzer sounds during operation.

### NOTICE

If any alarm indicator with audible alarm sound appears on the display during engine operation, stop the engine immediately. Determine the cause and repair the problem before you continue to operate the engine.

---

- Is there water, oil or fuel leakage, or are there any loose bolts?

Check the engine room periodically for any problems.

- Is there sufficient diesel fuel in the diesel fuel tank?

Replenish diesel fuel before leaving the dock to avoid running out of fuel during operation.

- When operating the engine at low speed for long periods of time, race the engine once every 2 hours.

### NOTICE

Racing the engine: With the gear in NEUTRAL, accelerate from the low-speed position to the high-speed position and repeat this process about five times. This is done to clean out carbon from the cylinders and the fuel injection valve. Neglecting to race the engine will result in poor smoke color and reduce engine performance.

---

- If possible, periodically operate the engine at near maximum engine speed while underway. This will generate higher exhaust temperatures, which will help clean out hard carbon deposits, maintaining engine performance and prolonging the life of the engine.

### NOTICE

Never turn off the battery switch (if equipped) or short the battery cables during operation. Damage to the electric system will result.

---

## SHUTTING DOWN THE ENGINE

### NOTICE

Never stop the engine abruptly during operation. Yanmar recommends that when shutting the engine down, allow the engine to run, without load, for 5 minutes. This will allow the engine components that operate at high temperatures, such as the exhaust system, to cool slightly before the engine itself is shut down.

1. Reduce the engine speed to low idle and put the shift control lever in NEUTRAL.
2. Accelerate from low speed to high speed and repeat five times. This will clean out the carbon from the cylinders and the fuel injection nozzles.
3. Allow the engine to run at low speed (approximately 1000 min<sup>-1</sup>) without load for five minutes.
4. With the key in the ON position, pull and hold the engine stop knob (**Figure 5, (1)**) until the engine has come to a complete stop. After the engine has stopped, turn the key switch to OFF.

Note: Continue to hold the engine stop knob until the engine is completely stopped. If the knob is released before the engine has completely stopped, it may restart.

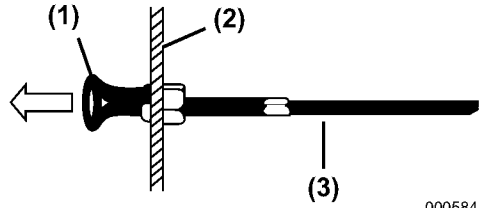

000584

**Figure 5**

- 1 – Engine Stop Knob**
- 2 – Bulkhead**
- 3 – Control Cable**

5. Turn off the master battery switch (if equipped).
6. Remove the key.
7. Close the fuel cock.
8. Close the seacock (if equipped).

### NOTICE

Be sure to close the seacock. Neglecting to close the seacock could allow water to leak into the boat and may cause it to sink.

Note: The engine may be stopped by raising the decompression lever, but avoid doing so except in times of emergency. The decompression lever releases compression pressure in the cylinder which causes the engine to stop. However, fuel injection does not stop and fuel continues to be pumped into the cylinder. This can lead to abnormal combustion when the engine is restarted and is not desirable.

### CHECKING THE ENGINE AFTER OPERATION

- Check that the key switch is in the OFF position and master battery switch (if equipped) is turned to OFF.
- Fill the fuel tank. *See Filling the Fuel Tank on page 28.*
- Close the seacock (if equipped).

#### **NOTICE**

Be sure to close the seacock. Neglecting to close the seacock could allow water to leak into the boat and may cause it to sink.

---

- If there is a risk of freezing, drain the seawater system. *See Drain Seawater Cooling System on page 72.*
- At temperatures below 0°C (32°F), drain seawater system and connect the engine heater (if equipped).

# PERIODIC MAINTENANCE

---

## INTRODUCTION

This section of the *Operation Manual* describes the procedures for proper care and maintenance of the engine.

## SAFETY PRECAUTIONS

Before performing any maintenance procedures within this section, read the following safety information and review the *Safety* section on page 3.

### WARNING

#### **Crush Hazard**



If the engine needs to be transported for repair, have a helper assist you attach it to a hoist and load it on a truck.

---

The engine lifting eyes are engineered to lift the weight of the marine engine only. Always use the engine lifting eyes when lifting the engine.

---

Additional equipment is necessary to lift the marine engine and marine gear together. Always use lifting equipment with sufficient capacity to lift the marine engine.

---

### **WARNING**

#### **Welding Hazard**

- Always turn off the battery switch (if equipped) or disconnect the negative battery cable and the leads to the alternator when welding on the equipment.
- Remove the engine control unit multi-pin connector. Connect the weld clamp to the component to be welded and as close as possible to the welding point.
- Never connect the weld clamp to the engine or in a manner which would allow current to pass through a mounting bracket.
- When welding is completed, reconnect the alternator and engine control unit prior to reconnecting the batteries.

---

#### **Entanglement Hazard**



Never leave the power switch on when you are servicing the engine. Someone may accidentally start the engine and not realize you are servicing it.

---

#### **Shock Hazard**



Always turn off the battery switch (if equipped) or disconnect the negative battery cable before servicing the equipment.

Always keep the electrical connectors and terminals clean. Check the electrical harnesses for cracks, abrasions, and damaged or corroded connectors.

---

Never use undersized wiring for the electrical system.

---

#### **Tool Hazard**

Always remove any tools or shop rags used during maintenance from the area before operation.

### **NOTICE**

Any part which is found defective as a result of inspection, or any part whose measured value does not satisfy the standard or limit, must be replaced.

---

Modifications may impair the engine's safety and performance characteristics and shorten the engine's life. Any alterations to this engine may void its warranty. Be sure to use Yanmar genuine replacement parts.

---

## PRECAUTIONS

### The Importance of Periodic Maintenance

Engine deterioration and wear occur in proportion to the length of time the engine has been in service and the conditions the engine is subjected to during operation. Periodic maintenance prevents unexpected downtime, reduces the number of accidents due to poor machine performance and helps extend the life of the engine.

### Performing Periodic Maintenance

#### WARNING

#### Exhaust Hazard.

**Never block windows, vents, or other means of ventilation if the engine is operating in an enclosed area. All internal combustion engines create carbon monoxide gas during operation. Accumulation of this gas within an enclosure could cause illness or even death. Make sure that all connections are tightened to specifications after repair is made to the exhaust system. Failure to comply could result in death or serious injury.**

### The Importance of Daily Checks

The Periodic Maintenance Schedule assumes that the daily checks are performed on a regular basis. Make it a habit to perform daily checks before the start of each operating day. *See Daily Checks on page 35.*

### Keep a Log of Engine Hours and Daily Checks

Keep a log of the number of hours the engine is run each day and a log of the daily checks performed. Also note the date, type of repair (e.g., replaced alternator) and parts used for any service needed between the periodic maintenance intervals. Periodic maintenance intervals are every 50, 150, 300 and 600 engine hours. Failure to perform periodic maintenance will shorten the life of the engine.

#### NOTICE

Failure to perform periodic maintenance will shorten the life of the engine and may void the warranty.

### Yanmar Replacement Parts

Yanmar recommends that you use genuine Yanmar parts when replacement parts are needed. Genuine replacement parts help ensure long engine life.

### Tools Required

Before you start any periodic maintenance procedure, make sure you have the tools you need to perform all of the required tasks.

### Ask Your Authorized Yanmar Marine Dealer or Distributor for Help

Our professional service technicians have the expertise and skills to help you with any maintenance or service related procedures you need help with.

## Tightening Fasteners

Use the correct amount of torque when you tighten fasteners on the engine. Applying excessive torque may damage the fastener or component and not enough torque may cause a leak or component failure. When working on critical components that require calibrated tools, special procedures and specific tightening sequences, consult with your Yanmar distributor or dealer.

### NOTICE



The tightening torque in the Standard Torque Chart should be applied only to the bolts with a "7" head (JIS strength classification: 7T). Apply 60% torque to bolts that are not listed. Apply 80% torque when tightened to aluminum alloy.

Bolt diameter x pitch (mm)		M6x1.0	M8x1.25	M10x1.5	M12x1.75	M14x1.5	M16x1.5
Tightening Torque	N·m	11.0 ± 1.0	26.0 ± 3.0	50.0 ± 5.0	90.0 ± 10.0	140.0 ± 10.0	230.0 ± 10.0
	kgf·m	1.1 ± 0.1	2.7 ± 0.3	5.1 ± 0.5	9.2 ± 1.0	14.3 ± 1.0	23.5 ± 1.0
	lb·ft	8.0 ± 0.7	19.0 ± 2.1	37 ± 3.6	66.0 ± 7.2	103 ± 7.2	170 ± 7.2



### PERIODIC MAINTENANCE SCHEDULE

Daily and periodic maintenance is important to keep the engine in good operating condition. The following is a summary of maintenance items by periodic maintenance intervals. Periodic maintenance intervals vary depending on engine application, loads, diesel fuel and engine oil used and are hard to establish definitively. The following should be treated only as a general guideline.

#### **NOTICE**

Establish a periodic maintenance plan according to the engine application and make sure to perform the required periodic maintenance at the intervals indicated. Failure to follow these guidelines will impair the engine's safety and performance characteristics, shorten the engine's life and may affect the warranty coverage on your engine.

*Consult authorized Yanmar Marine dealer or distributor for assistance when checking items marked with a ●.*

---

# PERIODIC MAINTENANCE

○: Check or Clean ◇: Replace ●: Contact your authorized Yanmar Marine dealer or distributor

System	Item	Periodic Maintenance Interval					
		Before Starting See Daily Checks on page 35.	Initial 50 Hours	Every 50 Hours	Every 150 Hours	Every 250 Hours or 1 Year	Every 1000 Hours or 4 Years
Whole	Visually inspecting the engine exterior	○					
Fuel System*	Inspecting the fuel level	○					
	Draining the fuel tank		○			○	
	Draining the fuel filter / water separator			○			
	Replacing the fuel filter element					◇	
	Inspecting the fuel injection timing						●
	Inspecting the fuel injection nozzle spray pattern					●	
Lubricating System	Inspecting the oil level	Engine	○				
		Marine Gear	○				
	Changing the oil	Engine		◇		◇	
		Marine Gear		◇		◇	
	Inspecting the function of the oil pressure warning lamp	○ During Operation					
	Replacing the engine oil filter element		◇			◇	
Cooling System	Inspecting the seawater outlet	During Operation					
	Inspecting the seawater pump impeller					○	◇
	Inspecting the zinc anode					◇	
Air Intake and Exhaust System	Cleaning the intake silencer (air filter)					○	
	Cleaning the exhaust / water mixing elbow					○	
	Cleaning the breather pipe					○	
	Inspecting the exhaust gas condition	○ During Operation					
Electrical System	Inspecting the function of the battery charge warning lamp	○					
	Inspecting the battery electrolyte level	○			○		
	Checking and adjusting the alternator V-belt tension		○			○	◇
	Checking the wiring connectors					○	
Engine Cylinder Head and Block	Inspecting for fuel, oil or engine leaks	○ After Starting					
	Tightening all major nuts and bolts						●
	Adjusting the intake / exhaust valve clearances		○			●	
Miscellaneous Items	Inspecting and adjusting the throttle and shift control cables		○			●	
	Adjusting the propeller shaft alignment		○				●

Note: These procedures are considered normal maintenance and are performed at the owner's expense.

## PERIODIC MAINTENANCE PROCEDURES

### After Initial 50 Hours of Operation

Perform the following maintenance after the initial 50 hours of operation.

- Draining the Fuel Tank
- Draining the Fuel Filter / Water Separator
- Changing the Engine Oil
- Replacing the Engine Oil Filter Element
- Changing the Marine Gear Oil
- Checking and Adjusting the Alternator V-Belt Tension
- Inspecting and Adjusting the Intake / Exhaust Valve Clearances
- Inspecting and Adjusting the Throttle and Shift Control Cables
- Adjusting the Propeller Shaft Alignment

### Draining the Fuel Tank

#### **⚠ WARNING**

When you are draining the fuel tank to perform maintenance, put an approved container under the opening to catch the fuel. Never use a shop rag to catch the fuel. Vapors from the rag are flammable and explosive. Wipe up any spills immediately. Wear eye protection. The fuel system is under pressure and fuel could spray out when you remove any fuel system component.

1. Put a pan under the drain cock (Figure 1, (2)) to catch the fuel.

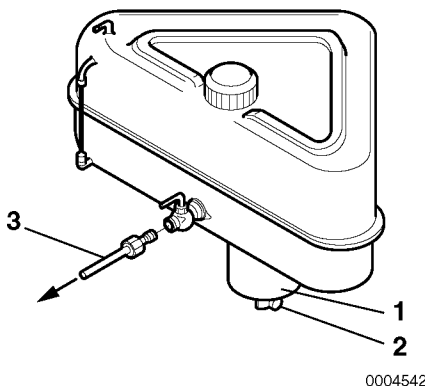

**Figure 1**

- 1 – Sediment Bowl
- 2 – Drain Cock
- 3 – Fuel Line to Engine

Note: Optional fuel tank shown. Actual equipment may differ.

2. Open the drain cock and drain water and sediment. Close the drain cock when the fuel is clean and free of water.

## PERIODIC MAINTENANCE

---

### Draining the Fuel Filter / Water Separator

#### WARNING

When removing any fuel system component to perform maintenance (such as changing the fuel filter), put an approved container under the opening to catch the fuel. Never use a shop rag to catch the fuel. Vapors from the rag are flammable and explosive. Wipe up any spills immediately. Wear eye protection. The fuel system is under pressure and fuel could spray out when removing any fuel system component.

---

1. Close the fuel cock.
2. Put a pan under the fuel / water separator.
3. Remove the fuel filter cover and drain any water and dirt collected inside.
4. Reassemble the fuel filter.
5. Purge air from the fuel system. *See Air Bleeding from the Fuel System After Starting Failure on page 41.*

### Changing the Engine Oil

The engine oil in a new engine becomes contaminated from the initial break-in of internal parts. It is very important that the initial oil replacement is performed as scheduled. This includes the replacement of the oil filter at this time.

#### WARNING

If you must drain the engine oil while it is still hot, stay clear of the hot engine oil to avoid being burned. Always wear eye protection.

---

1. Turn the engine OFF.
2. Remove the engine oil dipstick. Attach the oil drain pump (if equipped) and pump out the oil. For easier draining, remove the engine oil fill cap.

#### NOTICE

Prevent dirt and debris from contaminating engine oil. Carefully clean the dipstick and the surrounding area before you remove the dipstick.

---

3. Fill with new engine oil. *See Adding Engine Oil on page 31.*

#### NOTICE

Never mix different types of engine oil. This may adversely affect the lubricating properties of the engine oil. Never overfill. Overfilling may result in white exhaust smoke, engine overspeed or internal damage.

---

4. Perform a trial run and check for oil leaks.

- Approximately 10 minutes after stopping the engine, remove the oil dipstick and check the oil level. Add oil as necessary.

## Replacing the Engine Oil Filter Element

- Turn the engine off.
- Turn the engine oil filter (**Figure 2**) counterclockwise with a wrench.

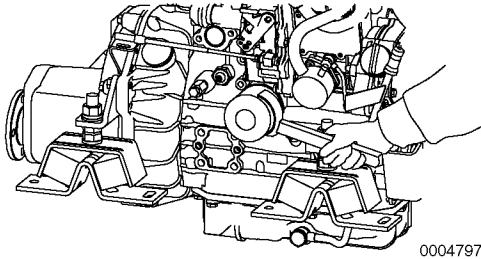

**Figure 2**

- Remove the engine oil filter.
- Clean the face of the filter mounting flange and apply a light coat of oil to the gasket of the new oil filter.
- Install a new filter element and tighten by hand until the seal touches the housing.
- Turn filter an additional 3/4 turn with a box wrench. Tighten to 20 to 24 N·m (14 to 17 lb-ft.).
- Perform a trial run and check for oil leaks.

## Changing the Marine Gear Oil

Note: Refer to the Operation Manual supplied with your marine gear or sail-drive unit for service and maintenance details.

During initial operation, the oil is quickly contaminated due to the initial wear of internal parts. The lubricating oil must therefore be replaced early.

- Remove the cap from the filler port and attach an oil drain pump. Drain the marine gear oil.
- Fill the marine gear with clean marine gear oil. *See Marine Gear Oil Specifications on page 31.*
- Perform a trial run and check for oil leaks.
- After approximately 10 minutes, stop the engine and check the oil level. Add oil if the level is too low.

## PERIODIC MAINTENANCE

---

### Checking and Adjusting the Alternator V-Belt Tension

Inadequate V-belt tension will cause reduced electrical power generation and increase the wear on the belt. Too much V-belt tension can cause damage to the alternator bearing.

#### **WARNING**

**Perform this check with the key removed (the power switch off) and the battery switch turned off to avoid contact with moving parts.**

#### **NOTICE**

Never get any oil on the belt. Oil on the belt causes slipping and stretching. Replace the belt if it is damaged.

1. Inspect the V-belt for any damage or wear and replace it if necessary.
2. Find a location on the belt that is in the middle of the two pulleys.
3. Check the tension by pushing on the middle of the belt.  
With proper tension, the belt should deflect 8 to 10 mm (approximately 3/8 in.).
4. Loosen the alternator bolt and move the alternator to adjust the V-belt tension, as required.
5. Hold the alternator in position and tighten the bolt.
6. Recheck tension by repeating step 3.

### Inspecting and Adjusting the Intake / Exhaust Valve Clearances

Proper adjustment is necessary to maintain the correct timing for opening and closing the valves. Improper adjustment will cause the engine to run noisily, resulting in poor engine performance and engine damage. Consult authorized Yanmar Marine dealer or distributor to adjust the intake / exhaust valve clearances.

### Inspecting and Adjusting the Throttle and Shift Control Cables

Various control levers and cables on the engine and marine gear are connected to the throttle and shift control console. The entire assembly loosens and stretches with prolonged use and initial break-in movements. It is dangerous to operate under these conditions. The throttle and shift control console should always be maintained in proper adjustment and should be inspected periodically.

#### **NOTICE**

The high speed stop bolt on the engine governor is set at the factory. Do not adjust. Adjustments to this bolt will void the engine warranty.

### ***Adjusting the Governor Control Cable***

1. With the engine off, move the throttle lever to the high speed position.
2. Check the governor control lever on the engine and verify that the lever is making contact with the high speed stop bolt.
3. Move the throttle lever to the low speed position.

4. Verify that the governor control lever on the engine is in contact with the low speed stop bolt.

If adjustment is needed, loosen the bracket that holds the control cable and adjust its position as necessary. Adjust the high speed position first and then the low speed position.

### NOTICE

The high speed stop bolt on the engine governor is set at the factory. Do not adjust. Adjustments to this bolt will void the engine warranty.

#### **Adjusting the Marine Gear Control Cable**

1. Check that the control lever moves to the correct position when the remote control cable handle is moved to the NEUTRAL, FORWARD and REVERSE positions.
2. Use the NEUTRAL position as the standard for adjustment. When there is deviation, loosen the bracket for the shift control cable on the marine gear and adjust its position as necessary.

#### **Adjusting the Propeller Shaft Alignment**

The flexible engine mounts are compressed slightly during initial engine operation and may cause misalignment between the engine and the propeller shaft.

After the first 50 hours of operation, the alignment should be checked and readjusted if necessary. This is considered normal maintenance and the adjustment requires specialized knowledge and techniques. Consult your authorized Yanmar Marine dealer or distributor.

### Every 50 Hours of Operation

After you complete the initial 50-hour maintenance procedures, perform the following procedures every 50 hours of operation.

- **Draining the Fuel Filter / Water Separator**

#### **Draining the Fuel Filter / Water Separator**

### ⚠ WARNING

When you remove any fuel system component to perform maintenance (such as changing the fuel filter), put an approved container under the opening to catch the fuel. Never use a shop rag to catch the fuel. Vapors from the rag are flammable and explosive. Wipe up any spills immediately. Wear eye protection. The fuel system is under pressure and fuel could spray out when you remove any fuel system component.

See *Draining the Fuel Filter / Water Separator* on page 54.

## Every 150 Hours of Operation

Perform the following maintenance every 150 hours of operation.

- Changing the Engine Oil
- Changing the Marine Gear Oil
- Inspecting the Battery Electrolyte Level

### Changing the Engine Oil

See *Changing the Engine Oil* on page 54.

### Changing the Marine Gear Oil

Refer to the *Operation Manual* supplied with your marine gear or sail-drive unit for service and maintenance details.

### Inspecting the Battery Electrolyte Level (Serviceable Batteries Only)

#### **WARNING**

Batteries contain sulfuric acid. Never allow battery fluid to come in contact with clothing, skin or eyes. Severe burns could result. Always wear safety goggles and protective clothing when servicing the battery. If battery fluid contacts the eyes and / or skin, immediately flush the affected area with a large amount of clean water and obtain prompt medical treatment.

#### **NOTICE**

Battery fluid tends to evaporate in high temperatures, especially in summer. In such conditions, inspect the battery earlier than specified.

1. Make sure the engine is off and the key is removed.

2. Turn the master battery switch to OFF (if equipped) or disconnect the negative (-) battery cable.
3. Remove the plugs and check the electrolyte level in all cells.

#### **NOTICE**

Never attempt to remove the covers or fill a maintenance-free battery.

4. If the electrolyte level is lower than the minimum fill level (**Figure 3, (1)**), fill with distilled water (**Figure 3, (2)**) (available locally) to the upper level (**Figure 3, (3)**) of the battery.

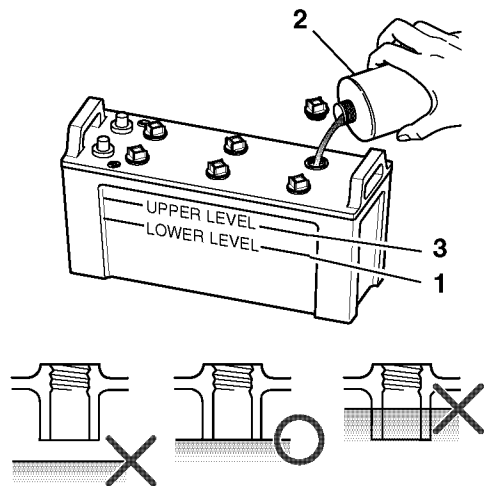

0004566

**Figure 3**

- 1 – Lower Level
- 2 – Battery Fluid
- 3 – Upper Level

If the engine cannot be started or the engine speed does not rise to rated output, measure the specific gravity of the battery with a hydrometer. The specific gravity of a fully charged battery is 1.27 or more at 20°C (68°F). Specific gravity of 1.24 or lower requires battery charging.



If charging the battery does not raise the specific gravity, replace the battery.

Note: The maximum fill level is approximately 10 to 15 mm (3/8 to 9/16 in.) above the plates.

### **NOTICE**

The standard alternator with the recommended battery is designed to produce electrical power for regular engine operations only. If power is being used for onboard lights and other systems, the charging system may be inadequate. Consult your authorized Yanmar Marine dealer or distributor.

---

### **Every 250 Hours of Operation**

Perform the following maintenance every 250 hours or 1 year of operation.

- **Draining the Fuel Tank**
- **Replacing the Fuel Filter Element**
- **Inspecting the Fuel Injection Nozzle Spray Pattern**
- **Replacing the Engine Oil Filter Element**
- **Inspecting the Seawater Pump Impeller**
- **Inspecting the Zinc Anode**
- **Cleaning the Intake Silencer (Air Filter)**
- **Cleaning the Exhaust / Water Mixing Elbow**
- **Cleaning the Breather Pipe**
- **Checking and Adjusting the Alternator V-Belt Tension**
- **Checking the Wiring Connectors**
- **Inspecting and Adjusting the Intake / Exhaust Valve Clearances**
- **Inspecting and Adjusting the Throttle and Shift Control Cables**

## PERIODIC MAINTENANCE

### Draining the Fuel Tank

See *Draining the Fuel Tank* on page 53.

### Replacing the Fuel Filter Element

#### **⚠ WARNING**

When you remove any fuel system component to perform maintenance (such as changing the fuel filter), put an approved container under the opening to catch the fuel. Never use a shop rag to catch the fuel. Vapors from the rag are flammable and explosive. Wipe up any spills immediately. Wear eye protection. The fuel system is under pressure and fuel could spray out when you remove any fuel system component.

When there is dirt in the fuel, the filter becomes clogged and the fuel will not flow easily. Check and replace the element.

1. Close the fuel cock of the fuel tank.
2. Place an approved container under the fuel filter.
3. Loosen the retaining ring (**Figure 4, (2)**) counterclockwise with a filter wrench.

Note: When removing the fuel filter, hold the bottom of the fuel filter with a cloth to prevent the fuel from spilling. Wipe up any spilled fuel immediately.

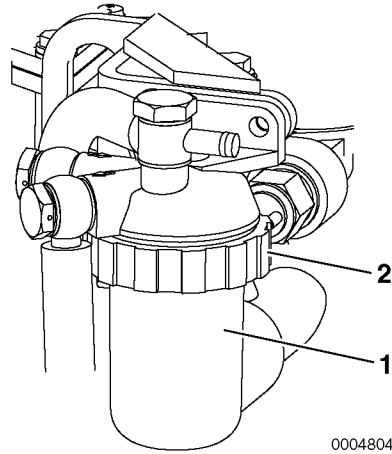

**Figure 4**

- 1 – Fuel Filter Housing**
- 2 – Retaining Ring**

4. Remove the fuel filter housing (**Figure 4, (1)**) and remove the element. Replace the element with a new one.
5. Apply a thin film of clean diesel fuel to the sealing surface of the new filter gasket.
6. Clean the inside of the fuel filter housing thoroughly, install the O-ring and hand-tighten the retainer ring. Use a filter wrench and tighten to 12 N·m (8.8 lb-ft).
7. Air will enter the fuel system when the filter is disassembled and should be bled. Bleed the fuel system. See *Air Bleeding from the Fuel System After Starting Failure* on page 41. Dispose of waste properly.

### Inspecting the Fuel Injection Nozzle Spray Pattern

Consult authorized Yanmar Marine dealer or distributor.

## Replacing the Engine Oil Filter Element

See *Replacing the Engine Oil Filter Element* on page 55.

## Inspecting the Seawater Pump Impeller

Note: The seawater pump impeller must be replaced every 1000 hours or every four years, even if it is not damaged.

The seawater pump impeller will wear and deteriorate with prolonged use. This will reduce its capacity to move cooling water through the engine. Inspect the seawater pump impeller at its scheduled maintenance interval or sooner if the discharge volume of seawater is diminished. Refer to **Figure 5** when performing this inspection.

1. Loosen the cover bolts and remove the pump side cover (**Figure 5, (7)**).

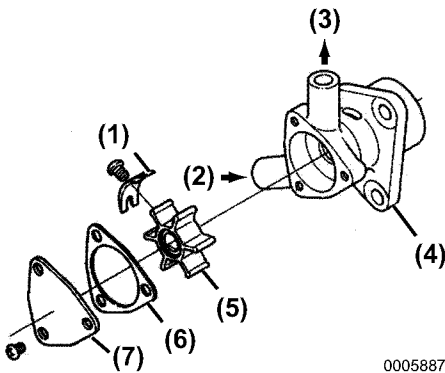

**Figure 5**

- 1 – Cam
- 2 – Inlet
- 3 – Outlet
- 4 – Seawater Pump Body
- 5 – Impeller
- 6 – Gasket
- 7 – Side Cover

2. Inspect the internal components of the pump.

- Inspect the impeller blades (**Figure 5, (5)**). Look for nicks, cracks and any evidence of damage. This includes excessive scratches and marring of the surface of the impeller blades.
- Inspect the condition of the pump body (**Figure 5, (4)**). Look for corrosion and evidence of structural damage to any surface that is in contact with the impeller blades. Make sure the walls of the pump chamber are smooth and free of gouges and corrosive pitting.

If no damage is found, reassemble the side cover.

Inspect the drain pipe under the pump during operation. If excessive amounts of water leak continuously, the oil seal needs to be replaced. Consult authorized Yanmar Marine dealer or distributor.

### NOTICE

During normal operation, the pump impeller rotates in a counterclockwise direction (**Figure 6, (1)**). Use caution when installing the impeller to ensure that all the blades of the impeller are set in the proper direction. When turning the engine over manually, do not reverse the normal direction of engine rotation or the blades of the seawater pump impeller (**Figure 6, (3)**) may be damaged.

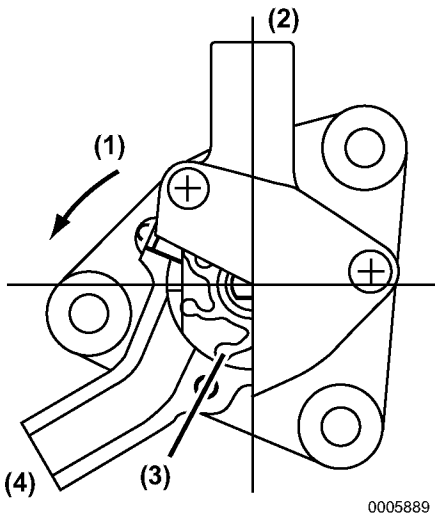

**Figure 6**

- 1 – Direction of Rotation**
- 2 – Outlet**
- 3 – Impeller**
- 4 – Inlet**

## Inspecting the Zinc Anode

The inspection intervals and replacement schedule for the zinc anode are determined by seawater characteristics and your operating environment. Inspect the zinc anode a minimum of every 300 hours of operation, but shorten this interval if your operating conditions show a higher corrosion rate.

Replace the zinc anode when its surface area has been reduced to less than half of its original size.

If neglected, seawater will begin to react with the internal surface areas of the engine cooling system. This will lead to seawater leaks, internal corrosion and eventual failure of engine components.

The zinc anode is located on the inside of the anode plug and is labeled “Anticorrosion Zinc.”

## Cleaning the Intake Silencer (Air Cleaner)

1. Open the clamps that secure the air cleaner cover.
2. Remove the air filter element.
3. Wash the air filter element with a mild neutral detergent and water.
4. Allow the element to dry completely.
5. Remove any debris from the filter housing and cover.
6. Reinstall the filter element and secure the cover with the clamps.

## Cleaning the Exhaust / Water Mixing Elbow

The mixing elbow is attached to the exhaust manifold. The exhaust gas is mixed with seawater in the mixing elbow.

1. Remove the mixing elbow.
2. Clean dirt and scale out of the exhaust and seawater passages.
3. If the mixing elbow is damaged, repair or replace it. Consult authorized Yanmar Marine dealer or distributor.
4. Inspect the gasket and replace if necessary.
5. Replace the mixing elbow with a new one every 500 hours or two years, whichever comes first, even if no damage is found.

## Cleaning the Breather Pipe

Consult authorized Yanmar Marine dealer or distributor.

## Checking and Adjusting the Alternator V-Belt Tension

*See Checking and Adjusting the Alternator V-Belt Tension on page 56.*

## Checking the Wiring Connectors

Consult authorized Yanmar Marine dealer or distributor.

## Inspecting and Adjusting the Intake / Exhaust Valve Clearances

See *Inspecting and Adjusting the Intake / Exhaust Valve Clearances on page 56*. Consult authorized Yanmar Marine dealer or distributor.

## Inspecting and Adjusting the Throttle and Shift Control Cables

See *Inspecting and Adjusting the Throttle and Shift Control Cables on page 56*.

## Every 1000 Hours of Operation

Perform the following maintenance every 1000 hours or every 4 years of operation, whichever comes first.

- **Inspecting the Fuel Injection Timing**
- **Inspecting the Seawater Pump Impeller**
- **Checking and Adjusting the Alternator V-Belt Tension**
- **Tightening All Major Nuts and Bolts**
- **Adjusting the Propeller Shaft Alignment**

### Inspecting the Fuel Injection Timing

Consult authorized Yanmar Marine dealer or distributor.

### Inspecting the Seawater Pump Impeller

See *Inspecting the Seawater Pump Impeller on page 61*.

### Checking and Adjusting the Alternator V-Belt Tension

See *Checking and Adjusting the Alternator V-Belt Tension on page 56*.

### Tightening All Major Nuts and Bolts

See *Tightening Fasteners on page 50* or consult authorized Yanmar Marine dealer or distributor.

### Adjusting the Propeller Shaft Alignment

See *Adjusting the Propeller Shaft Alignment on page 57*. Consult authorized Yanmar Marine dealer or distributor.

**This Page Intentionally Left Blank**

# TROUBLESHOOTING

---

## SAFETY PRECAUTIONS

Before performing any troubleshooting procedures within this section, review the *Safety* section on page 3.

If a problem occurs, stop the engine immediately. Refer to the Symptom column in the Troubleshooting Chart to identify the problem.

## TROUBLESHOOTING AFTER STARTING

Just after the engine has started, check the following items at a low engine speed:

### **Is sufficient water being discharged from the seawater outlet pipe?**

If the discharge is low, stop the engine immediately. Identify the cause and repair.

### **Is the smoke color normal?**

The continuous emission of black exhaust smoke indicates engine overloading. This shortens the engines life and should be avoided.

### **Are there abnormal vibrations or noise?**

Depending on the hull structure, engine and hull resonance may suddenly increase at certain engine speed ranges, causing heavy vibrations. Avoid operation in this speed range. If any abnormal sounds are heard, stop the engine and inspect for cause.

### **Alarm sounds during operation.**

If the alarm sounds during operation, lower the engine speed immediately, check the alarm lamps and stop the engine for repairs.

## TROUBLESHOOTING

---

### Is there water, oil or fuel leakage? Are there any loose bolts or connections?

Check the engine room daily for any leaks or loose connections.

### Is there sufficient fuel in the fuel tank?

Refill fuel in advance to avoid running out of fuel. If the tank runs out of fuel, bleed the fuel system. See *Air Bleeding from the Fuel System After Starting Failure on page 41*.

When operating the engine at low speed for long periods of time, race the engine once every 2 hours. Racing the engine with the clutch in NEUTRAL, accelerate from the low-speed position to the high-speed position and repeat this process about five times. This is done to clean out carbon from the cylinders and the fuel injection valves.

### NOTICE

Neglecting to race the engine will result in poor smoke color and reduce engine performance.

---

Periodically operate the engine near maximum speed while underway. This will generate higher exhaust temperatures, which will help clean out hard carbon deposits, maintain engine performance and prolong the life of the engine.

## TROUBLESHOOTING INFORMATION

If the engine does not operate properly, refer to the *Troubleshooting Chart on page 67* or consult authorized Yanmar Marine dealer or distributor.

Supply the authorized Yanmar Marine dealer or distributor with the following information:

- Model name and serial number of your engine
- Boat model, hull material, size (tons)
- Use, type of boating, number of hours run
- Total number of operation hours (refer to hourmeter), age of boat
- The operating conditions when the problem occurs:
  - Engine speed (min<sup>-1</sup>)
  - Smoke color
  - Type of diesel fuel
  - Type of engine oil
  - Any abnormal noises or vibration
  - Operating environment such as high altitude or extreme ambient temperatures, etc.
  - Engine maintenance history and previous problems
  - Other factors that contribute to the problem



## TROUBLESHOOTING CHART

Symptom	Probable Cause	Measure	Reference
Indicators light on the instrument panel and alarm sounds during operation.	Shift to low speed operation immediately, and check which indicator has come on. Stop the engine and inspect. If no abnormality is identified and there is no problem with operation, return to port at lowest speed and consult authorized Yanmar Marine dealer or distributor.		
• Engine oil low pressure alarm indicator lights	Engine oil level is low.	Check engine oil level. Add or replace.	<i>See Checking the Engine Oil on page 30.</i>
	Engine oil filter is clogged.	Replace engine oil filter. Replace engine oil.	<i>See Replacing the Engine Oil Filter Element on page 55.</i>
• Water in sail-drive seal indicator lights	Rubber sail-drive seal is broken.	Consult authorized Yanmar Marine dealer or distributor.	—
Coolant High Temperature Alarm lights	Insufficient seawater discharge causing temperature to rise	Check seawater system.	—
	Contamination inside cooling system	Consult authorized Yanmar Marine dealer or distributor.	—
Faulty warning devices	Do not operate the engine if alarm devices are not repaired. Serious accidents may result if abnormalities are not identified because of faulty indicators or alarm.		
Indicators Do Not Light			
• The tachometer does not turn on, even though the power switch is turned on	No electrical current available. The battery switch is turned off, the fuse (3 A) on the instrument panel is burned out or the circuit is broken.	Consult authorized Yanmar Marine dealer or distributor.	—
One of the indicators does not go out.	Sensor switch is faulty.	Consult authorized Yanmar Marine dealer or distributor.	—
Battery low charge indicator does not go out during operation.	V-belt is loose or broken.	Replace V-belt or adjust tension.	<i>See Checking and Adjusting the Alternator V-Belt Tension on page 56.</i>
	Battery is defective.	Check battery fluid level and specific gravity, or replace battery.	<i>See Inspecting the Battery Electrolyte Level (Serviceable Batteries Only) on page 58.</i>
	Alternator power generation failure.	Consult authorized Yanmar Marine dealer or distributor.	—

# TROUBLESHOOTING

Symptom	Probable Cause	Measure	Reference
Starting Failures:			
Starter turns but engine does not start.	No fuel	Add fuel. Bleed fuel system. Ensure that fuel shut-off valve is open.	<i>See Filling the Fuel Tank on page 28.</i>
	Fuel filter is clogged.	Replace filter element.	<i>See Replacing the Fuel Filter Element on page 60.</i>
	Improper fuel	Replace with recommended fuel.	<i>See Diesel Fuel Specifications on page 26.</i>
	Problem with fuel injection	Consult authorized Yanmar Marine dealer or distributor.	—
	Compression leakage from intake / exhaust valve	Consult authorized Yanmar Marine dealer or distributor.	—
Starter does not turn or turns slowly (engine can be turned manually).	Faulty clutch position	Shift to NEUTRAL and start.	<i>See Restarting After Starting Failure on page 40.</i>
	Insufficient battery charge	Check fluid level. Recharge. Replace.	<i>See Inspecting the Battery Electrolyte Level (Serviceable Batteries Only) on page 58</i>
	Cable terminal contact failure	Remove corrosion from terminals. Tighten battery cables.	<i>See Inspecting the Battery Electrolyte Level (Serviceable Batteries Only) on page 58.</i>
	Faulty safety switch device	Consult authorized Yanmar Marine dealer or distributor.	—
	Faulty starter switch	Consult authorized Yanmar Marine dealer or distributor.	—
	Power lacking because accessory drive is engaged	Consult authorized Yanmar Marine dealer or distributor.	—
Engine cannot be turned manually.	Internal parts seized	Consult authorized Yanmar Marine dealer or distributor.	—

Symptom	Probable Cause	Measure	Reference
Abnormal Exhaust Color:			
<ul style="list-style-type: none"> <li>• Black smoke</li> </ul>	Engine is overloaded.	Consult authorized Yanmar Marine dealer or distributor.	—
	Improper propeller matching	Consult authorized Yanmar Marine dealer or distributor.	—
	Dirty intake silencer (air cleaner)	Clean element.	<i>See Cleaning the Intake Silencer (Air Cleaner) on page 62.</i>
	Improper fuel	Replace with recommended fuel.	<i>See Diesel Fuel Specifications on page 26.</i>
	Faulty spraying of fuel injector	Consult authorized Yanmar Marine dealer or distributor.	—
	Incorrect intake / exhaust valve clearance	Consult authorized Yanmar Marine dealer or distributor.	—
<ul style="list-style-type: none"> <li>• White smoke</li> </ul>	Improper fuel	Replace with recommended fuel.	<i>See Diesel Fuel Specifications on page 26.</i>
	Faulty spraying of fuel injector	Consult authorized Yanmar Marine dealer or distributor.	—
	Fuel injection timing off	Consult authorized Yanmar Marine dealer or distributor.	—
	Engine burning oil (excessive consumption)	Consult authorized Yanmar Marine dealer or distributor.	—

**This Page Intentionally Left Blank**

# LONG-TERM STORAGE

---

If the engine will not be used for an extended period of time, special measures should be taken to protect the cooling system, fuel system and combustion chamber from corrosion and the exterior from rusting.

The engine can normally stand idle for up to 6 months. If it remains unused for longer than this, please contact your authorized Yanmar Marine dealer or distributor.

Before performing any storage procedures within this section, review the *Safety* section on page 3.

In cold temperatures or before long-term storage, be sure to drain the seawater from the cooling system.

## NOTICE

If seawater is left inside of the engine, it may freeze and damage parts of the cooling system when the ambient temperature is below 0°C (32°F).

---

## PREPARE ENGINE FOR LONG-TERM STORAGE

Note: If the engine is close to a periodic maintenance interval, perform those maintenance procedures before putting the engine into long-term storage.

1. Wipe off any dust or oil from the outside of engine.
2. Drain water from fuel filters.
3. Drain fuel tank completely or fill the tank to prevent condensation.
4. Grease the exposed areas and joints of the remote control cables and the bearings of the remote control handle.
5. Seal the intake silencer, exhaust pipe, etc. to prevent moisture or contamination from entering engine.
6. Completely drain bilge in hull bottom.
7. Waterproof the engine room to prevent rain or seawater from entering.
8. Charge the battery once a month to compensate for battery's self-discharge.
9. Remove the key from the key switch and cover the key switch with the moisture cap (if equipped).

## LONG-TERM STORAGE

### DRAIN SEAWATER COOLING SYSTEM

In cold temperatures or before long-term storage, be sure to drain the seawater from the cooling system.

1. Put a pan under the seawater drain cocks.
2. Loosen the drain cock at the side of the thermostat cover and drain the water from the inside.
3. Loosen the three bolts holding the side cover **(Figure 1, (7))** of the seawater pump. Remove the cover and drain the seawater from the pump body **(Figure 1, (4))**. Reinstall the cover and retighten the bolts when finished.

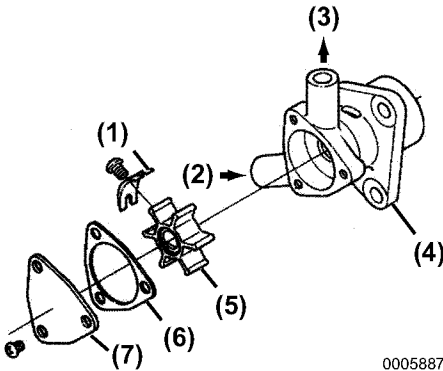

*Figure 1*

- 1 – Cam
- 2 – Inlet
- 3 – Outlet
- 4 – Seawater Pump Body
- 5 – Impeller
- 6 – Gasket
- 7 – Side Cover

4. Close the drain cock.

### RETURNING THE ENGINE TO SERVICE

1. Replace the oil and the oil filter before running the engine.
2. Supply fuel if the fuel in the fuel tank was removed, and prime the fuel system.
3. Operate the engine at idle speed for 1 minute.
4. Check fluid levels and check engine for leaks.

# **SPECIFICATIONS**

---

## **PRINCIPAL ENGINE SPECIFICATIONS**

# SPECIFICATIONS

## 1GM10 Engine

Type		Vertical 4-cycle water-cooled diesel engine			
Combustion System		Swirl pre-combustion chamber			
Number of Cylinders		1			
Bore and Stroke		75 mm x 72 mm (2.95 in. x 2.83 in.)			
Displacement		0.318 L (19.4 cu. in.)			
Continuous Rating Output	Output at Crankshaft / Engine Speed	5.9 kW (8 hp metric) / 3400 min <sup>-1</sup> *			
Maximum Rating Output	Output at Crankshaft / Engine Speed	6.7 kW (9.1 hp metric) / 3600 min <sup>-1</sup> * 6.55 kW (8.9 hp metric) / 3600 min <sup>-1</sup> **			
Fuel Injection Timing (BTDC)		15° ± 1°			
Fuel Injection Pressure		16.7 ± 0.5 MPa (2347- 2489 psi)			
Main Power Take Off		At flywheel end			
Front Power Take Off		At crankshaft V-pulley end			
Direction of Rotation	Crankshaft	Counterclockwise viewed from stern			
	Propeller Shaft (Ahead)	Clockwise viewed from stern			
Cooling System		Direct seawater cooling (Rubber impeller water pump)			
Lubrication System		Forced lubrication system			
Starting System	Type	Electric and manual			
	Starting Motor	12V DC, 1.0 kW			
	AC Generator	12V, 35A			
Marine Gear System	Model	KM2P			
	Type	Mechanical cone clutch			
	Reduction Ratio	Forward	2.21 : 1	2.62 : 1	3.22 : 1
		Reverse	3.06 : 1	3.06 : 1	3.06 : 1
		Forward	1540 min <sup>-1</sup>	1298 min <sup>-1</sup>	1055 min <sup>-1</sup>
		Reverse	1113 min <sup>-1</sup>	1113 min <sup>-1</sup>	1113 min <sup>-1</sup>
	Lubricating Oil Capacity	0.3 L (0.32 qt)			
Weight	9.8 kg (22.7 lb)				
Dimensions	Overall Length	554 mm (21.8 in.)			
	Overall Width	410 mm (16.1 in.)			
	Overall Height	485 mm (19.1 in.)			
Engine Lubricating Oil Capacity (8° Rake Angle)	Total	1.5 L (1.59 qt)			
	Effective	0.8 L ( 0.85 qt)			
Engine Weight with Marine Gear		76 kg ( 167 lb)			

\* Rating Condition: Temperature of fuel: 25°C at fuel pump inlet; ISO 3046-1

\*\* Rating Condition: Temperature of fuel: 40°C at fuel pump inlet; ISO 8665

Note: Density of fuel: 0.842g/cm<sup>3</sup> at 15°C. Fuel temperature at the inlet of the fuel injection pump.  
1 hp metric = 0.7355 kW



**1GM10C Engine**

Type		Vertical 4-cycle water-cooled diesel engine		
Combustion System		Swirl pre-combustion chamber		
Number of Cylinders		1		
Bore and Stroke		75 mm x 72 mm (2.95 in. x 2.83 in.)		
Displacement		0.318 L (19.4 cu. in.)		
Continuous Rating Output	Output at Crankshaft / Engine Speed	5.9 kW (8 hp metric) / 3400 min <sup>-1</sup> *		
Maximum Rating Output	Output at Crankshaft / Engine Speed	6.7 kW (9.1 hp metric) / 3600 min <sup>-1</sup> * 6.55 kW (8.9 hp metric) / 3600 min <sup>-1</sup> **		
Fuel Injection Timing (BTDC)		15° ± 1°		
Fuel Injection Pressure		16.7 ± 0.5 MPa (2347-2489 psi)		
Main Power Take Off		At flywheel end		
Front Power Take Off		At crankshaft V-pulley end		
Direction of Rotation	Crankshaft	Counterclockwise viewed from stern		
	Propeller Shaft (Ahead)	Clockwise viewed from stern		
Cooling System		Direct seawater cooling (Rubber impeller water pump)		
Lubrication System		Forced lubrication system		
Starting System	Type	Electric and manual		
	Starting Motor	12V DC, 1.0 kW		
	AC Generator	12V, 35A		
Marine Gear System	Model	SD25		
	Type	Sail-Drive unit, dog-type clutch		
	Reduction Ratio	Forward	2.64 : 1	
		Reverse	2.64 : 1	
	Propeller Speed	Forward	1287 min <sup>-1</sup>	
		Reverse	1287 min <sup>-1</sup>	
	Lubricating Oil Capacity	2.2 L (2.32 qt)		
Weight	30 kg (66.1 lb)			
Dimensions	Overall Length	412 mm (16.22 in.)		
	Overall Width	410 mm (16.14 in.)		
	Overall Height	485 mm (19.09 in.)		
Engine Lubricating Oil Capacity (8° Rake Angle)	Total	1.5 L (1.59 qt)		
	Effective	0.8 L (0.85 qt)		
Engine Weight with Sail-Drive		104 kg (229 lb)		

\* Rating Condition: Temperature of fuel: 25°C at fuel pump inlet; ISO 3046-1

\*\* Rating Condition: Temperature of fuel: 40°C at fuel pump inlet; ISO 8665

Note: Density of fuel: 0.842g/cm<sup>3</sup> at 15°C. Fuel temperature at the inlet of the fuel injection pump.  
1 hp metric = 0.7355 kW

# SPECIFICATIONS

## 1GM10V Engine

Type		Vertical 4-cycle water-cooled diesel engine			
Combustion System		Swirl pre-combustion chamber			
Number of Cylinders		1			
Bore and Stroke		75 mm x 72 mm (2.95 in. x 2.83 in.)			
Displacement		0.318 L (19.4 cu. in.)			
Continuous Rating Output	Output at Crankshaft / Engine Speed	5.9 kW (8 hp metric) / 3400 min <sup>-1</sup> *			
Maximum Rating Output	Output at Crankshaft / Engine Speed	9.7 kW (9.1 hp metric) / 3600 min <sup>-1</sup> * 6.55 kW (8.9 hp metric) / 3600 min <sup>-1</sup> **			
Fuel Injection Timing (BTDC)		15° ± 1°			
Fuel Injection Pressure		16.7 ± 0.5 MPa (2347-2489 psi)			
Main Power Take Off		At flywheel end			
Front Power Take Off		At crankshaft V-pulley end			
Direction of Rotation	Crankshaft	Counterclockwise viewed from stern			
	Propeller Shaft (Ahead)	Clockwise viewed from stern			
Cooling System		Direct seawater cooling (Rubber impeller water pump)			
Lubrication System		Forced lubrication system			
Starting System	Type	Electric and manual			
	Starting Motor	12 VDC, 1.0 kW			
	AC Generator	12V, 35A			
Marine Gear System	Model	KM3V			
	Type	V-Drive, Mechanical cone clutch (15°)			
	Reduction Ratio	Forward	2.36	2.61	3.20
		Reverse	3.16	3.16	3.16
	Propeller Speed DIN 6270A Rating	Forward	1441 min <sup>-1</sup>	1303 min <sup>-1</sup>	1063 min <sup>-1</sup>
		Reverse	1076 min <sup>-1</sup>	1076 min <sup>-1</sup>	1076 min <sup>-1</sup>
	Lubricating Oil Capacity	0.3 L (0.32 qt)			
Weight	19 kg (41.9 lb)				
Dimensions	Overall Length	680 mm (26.77 in.)			
	Overall Width	450 mm (17.71 in.)			
	Overall Height	554 mm (21.81 in.)			
Lubricating Oil Capacity (8° Rake Angle)	Total	1.5 L (1.59 qt)			
	Effective	0.8 L (0.85 qt)			
Engine Weight with Marine Gear		90 kg (198 lb)			

\* Rating Condition: Temperature of fuel: 25°C at fuel pump inlet; ISO 3046-1

\*\* Rating Condition: Temperature of fuel: 40°C at fuel pump inlet; ISO 8665







Note: Density of fuel: 0.842g/cm<sup>3</sup> at 15°C. Fuel temperature at the inlet of the fuel injection pump.

1 hp metric = 0.7355 kW

# SYSTEM DIAGRAMS

---

## PIPING DIAGRAMS

Notation	
	Screw Joint (Union)
	Spherical Pipe Joint
	Drilled Hole
	Cooling Seawater Piping
	Lubricating Oil Piping
	Fuel Oil Piping
STP	Steel Pipe
RH	Rubber Hose
VH	Vinyl Pipe

1GM10 Piping Diagram

00059933

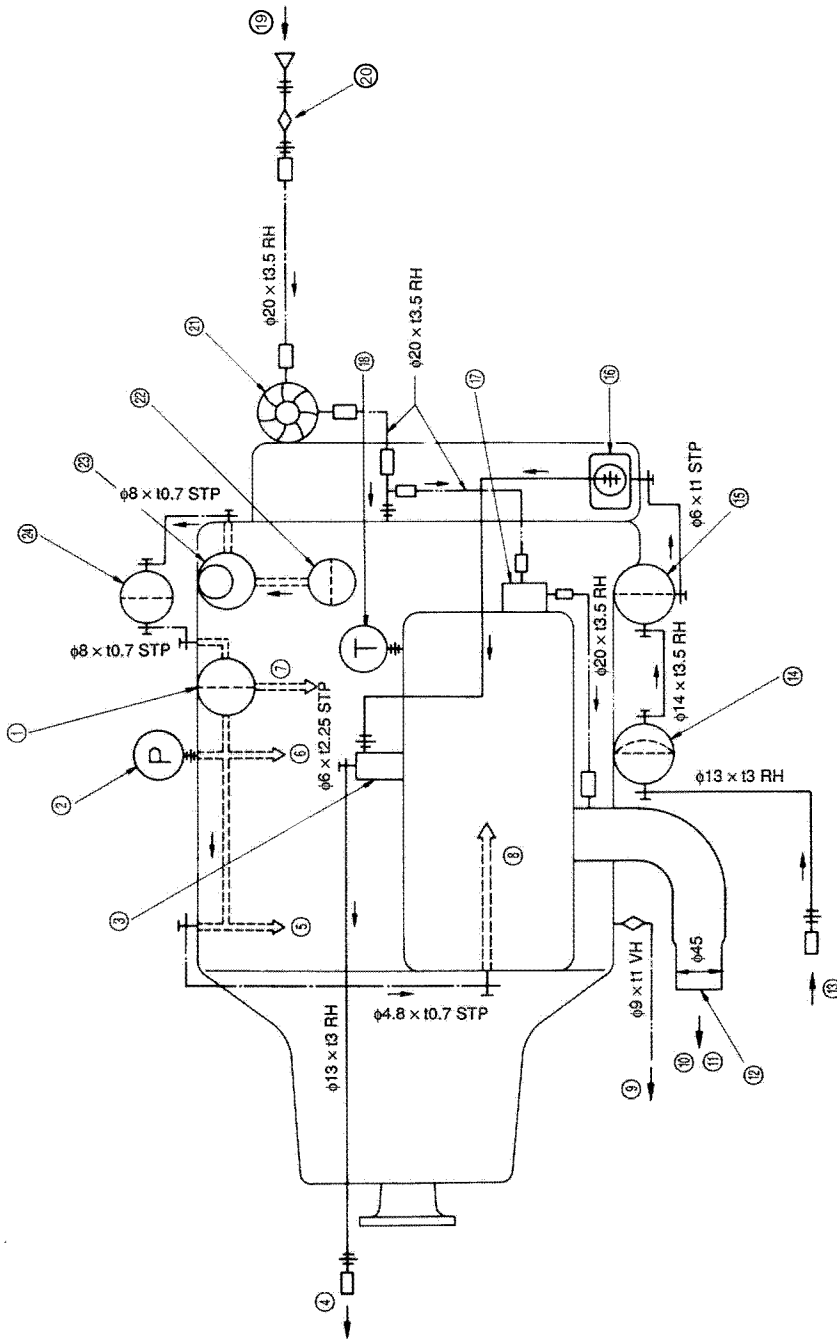

Figure 1



WIRING DIAGRAMS

1GM10 Series A-Type Instrument Panel

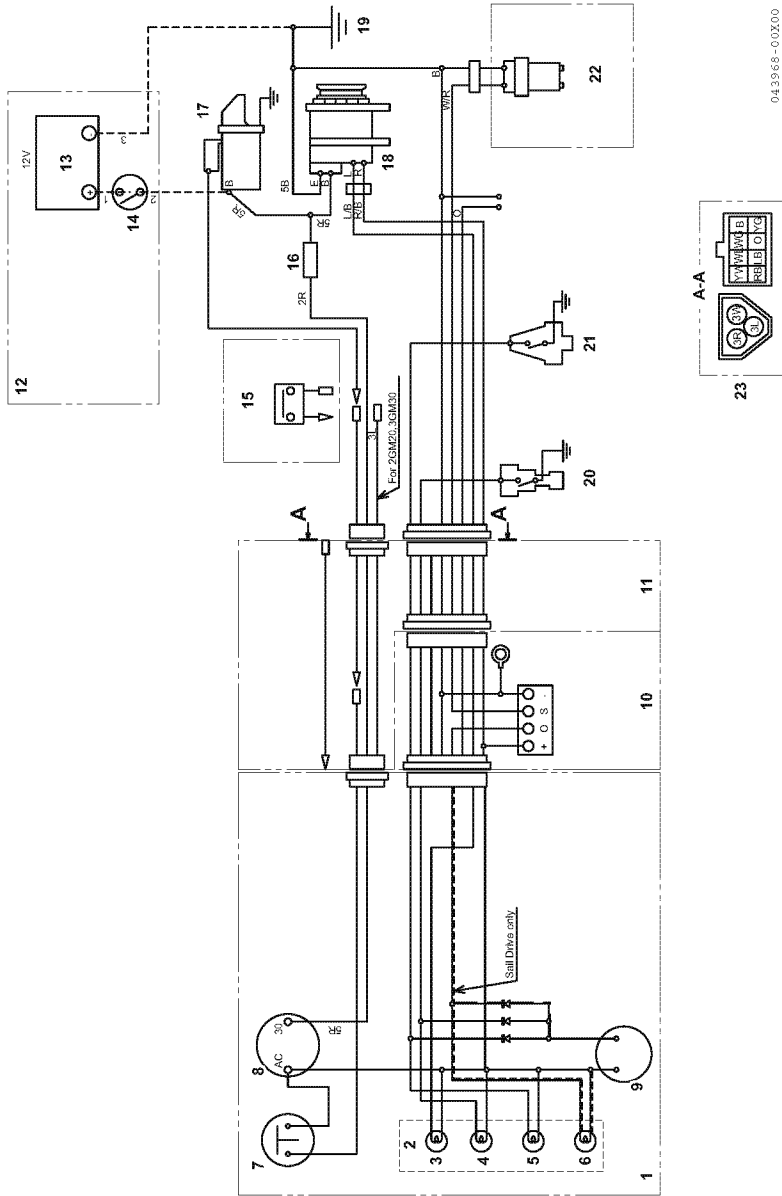

Figure 2

Color Coding		Engine Harness
R	Red	+
B	Black	-
W	White	Ignition
L	Blue	Air Heater / Glow (option)
RB	Red / Black	Alternator Exciter
LB	Blue / Black	Alternator Charge Alarm
YW	Yellow / White	Engine Oil Pressure Alarm
YB	Yellow / Black	Engine Oil Pressure
YG	Yellow / Green	Sail Drive Seal
WL	White / Blue	Water Temperature Alarm
O	Orange	Pulse for Tachometer

- 1 – Instrument panel (A Type)
- 2 – Alarm lamps (3 to 6)
- 3 – Battery low charge indicator
- 4 – Cooling water high temperature indicator
- 5 – Engine oil low pressure indicator
- 6 – Water in sail drive seal indicator
- 7 – Start switch (Push button)
- 8 – Key switch
- 9 – Buzzer
- 10 – Water in sail drive seal sensor amplifier (Sail drive only)
- 11 – Wire harness
- 12 – Procured by customer
- 13 – Battery
- 14 – Battery switch
- 15 – Neutral switch (Option)
- 16 – Fuse 30A
- 17 – Starter
- 18 – Alternator
- 19 – Ground
- 20 – Cooling water temperature switch
- 21 – Engine oil pressure switch
- 22 – Water in sail drive seal sensor (Sail drive only)
- 23 – Details of coupler (View from A-A)

## 1GM10 Series B20-Type Instrument Panel

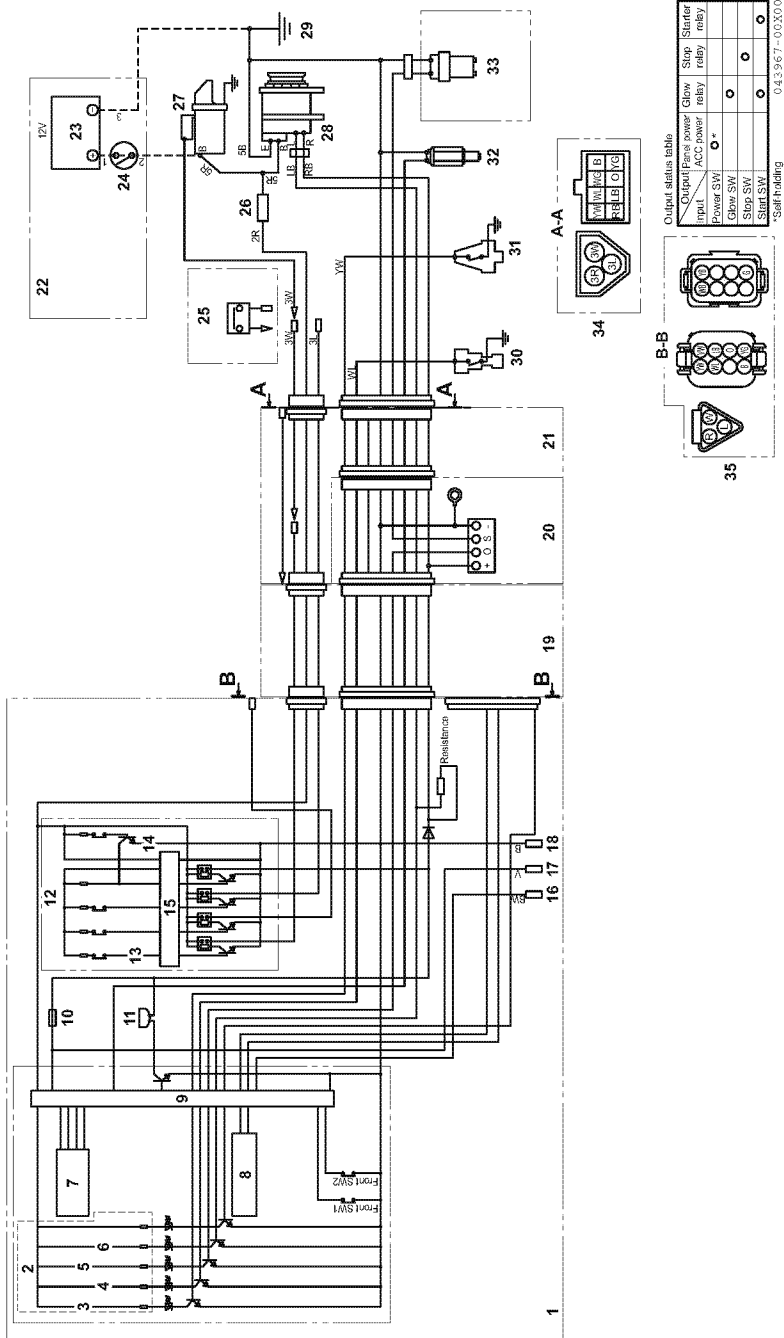

Figure 3



Color Coding		Engine Harness
R	Red	+
B	Black	-
W	White	Ignition
L	Blue	Air Heater / Glow (option)
RB	Red / Black	Alternator Exciter
LB	Blue / Black	Alternator Charge Alarm
YW	Yellow / White	Engine Oil Pressure Alarm
YB	Yellow / Black	Engine Oil Pressure
YG	Yellow / Green	Sail Drive Seal
WL	White / Blue	Water Temperature Alarm
WB	White / Black	Water Temperature
V	Purple	ACC Power
BW	Blue / White	Fuel Tank Level
O	Orange	Pulse for Tachometer
WBr	White / Brown	Electric Stop

- 1 – Instrument panel B20 (Option)
- 2 – Alarm lamps (3 to 6)
- 3 – Engine oil low pressure indicator
- 4 – Cooling water high temperature indicator
- 5 – Water in sail drive seal indicator
- 6 – Battery low charge indicator
- 7 – Tachometer
- 8 – Segmented display
- 9 – Control unit (Tacho gauge)
- 10 – Fuse 3A
- 11 – Buzzer
- 12 – Switch module (13 to 14)
- 13 – Start switch
- 14 – Power switch
- 15 – Control unit (Switch module)
- 16 – Fuel tank level sensor input
- 17 – ACC power
- 18 – ACC GND
- 19 – Conversion harness
- 20 – Water in sail drive seal sensor amplifier (Sail drive only)
- 21 – Wire harness
- 22 – Procured by customer
- 23 – Battery
- 24 – Battery switch
- 25 – Neutral switch (Option)
- 26 – Fuse 30A
- 27 – Starter
- 28 – Alternator
- 29 – Ground
- 30 – Cooling water temperature switch
- 31 – Engine oil pressure switch
- 32 – Tacho sender
- 33 – Water in sail drive seal sensor (Sail drive only)
- 34 – Details of coupler (Wire harness, view from A-A)
- 35 – Details of coupler (Wire harness, view from B-B)

**Declaration of Conformity for Recreational Craft Propulsion Engines (inboard engines and stern drive engines without integral exhaust) with the requirements of Directive 2013/53/EU**  
(To be completed by manufacturer or, if mandated, authorised representative)

Name of engine manufacturer: Yanmar Co., Ltd.

Address: 1-32, Chayamachi, Kita-ku, Osaka

Town: \_\_\_\_\_ Post Code: 530-8311 Country: Japan

Name of Authorised Representative: Yanmar Marine International B.V.

Address: Brugplein 11

Town: Almere Post Code: 1332 BS Country: the Netherlands

Name of Notified Body for **exhaust emission assessment**: Dutch Certification Institute (DCI)

Address: Nipkowweg 9

Town: Joure Post Code: 8500 AB Country: the Netherlands ID Number: 0613

Conformity assessment module used for exhaust emissions:  B+C/C1  B+D  B+E  B+F  G  H  
or engine type-approved according to:  Directive 97/68/EC  EC Regulation No 595/2009

Other Community Directives applied: 2004/108/EC

**DESCRIPTION OF ENGINE TYPE(s)**

**Main Propulsion ExhaustType:**

- With integral exhaust  
 Without integral exhaust

**Combustion Type:**

- Internal combustion, Diesel (CI)  
 Internal combustion, Petrol (SI)  
 Other

**Combustion cycle:**

- 2 stroke  
 4 stroke

**IDENTIFICATION OF ENGINE(S) COVERED BY THIS DECLARATION OF CONFORMITY**

Name of engine model or engine family:	Unique engine identification number(s) or engine family code(s)	EC Type-examination certificate or type-approval certificate number
Engine family: RCD2-1GM10X1 Engine models: 1GM10, 1GM10C, 1GM10V		DCI-CE-2013/53/EU-1619*00

This declaration of conformity is issued under the sole responsibility of the manufacturer. I declare on behalf of the manufacturer that the recreational craft propulsion engine(s) mentioned above fulfil(s) the requirements specified in Article 4 (1) and Annex I of Directive 2013/53/EU.

Name / function: Shiori Nagata, President  
(identification of the person empowered to sign on behalf of the engine manufacturer or his authorised representative)

Signature and title:  
(or an equivalent marking)



Date and place of issue: (yy/mm/dd) 16/10/31, Yanmar Marine International B.V.

Essential requirements  (reference to relevant articles in Annex IB & IC of the Directive)	Harmonised standards Full Application	Harmonised standards Partial Application, see tech. file	Other reference documents <sup>1</sup> Full Application	Other reference documents Partial Application, see tech. file	Other proof of conformity See technical file	Specify the harmonised <sup>2</sup> standards or other reference documents used  (with year of publication like "EN ISO 8666:2002")
<b>Annex I.A - Design and Construction of products</b>						
Inboard Engine (Annex I A. 5.1.1)	<input type="checkbox"/>	<input type="checkbox"/>	<input type="checkbox"/>	<input type="checkbox"/>	<input type="checkbox"/>	
Ventilation (Annex I A.5.1.2)	<input type="checkbox"/>	<input type="checkbox"/>	<input type="checkbox"/>	<input type="checkbox"/>	<input type="checkbox"/>	
Exposed parts (Annex I A.5.1.3)	<input type="checkbox"/>	<input type="checkbox"/>	<input type="checkbox"/>	<input type="checkbox"/>	<input type="checkbox"/>	
Fuel system - General (Annex I A.5.2.1)	<input type="checkbox"/>	<input type="checkbox"/>	<input type="checkbox"/>	<input type="checkbox"/>	<input type="checkbox"/>	
Electrical System (Annex I A.5.3)	<input type="checkbox"/>	<input type="checkbox"/>	<input type="checkbox"/>	<input type="checkbox"/>	<input type="checkbox"/>	
Steering System (Annex I A.5.4)	<input type="checkbox"/>	<input type="checkbox"/>	<input type="checkbox"/>	<input type="checkbox"/>	<input type="checkbox"/>	
Fire protection - General (Annex I A.5.6.1)	<input type="checkbox"/>	<input type="checkbox"/>	<input type="checkbox"/>	<input type="checkbox"/>	<input type="checkbox"/>	
Discharge prevention (Annex I A.5.8)	<input type="checkbox"/>	<input type="checkbox"/>	<input type="checkbox"/>	<input type="checkbox"/>	<input type="checkbox"/>	
<b>Annex I.B – Exhaust Emissions</b>						
Propulsion Engine Identification (Annex I B.1)	<input type="checkbox"/>	<input type="checkbox"/>	<input type="checkbox"/>	<input type="checkbox"/>	<input type="checkbox"/>	
Exhaust Emission Requirements (Annex I B. 2)	<input checked="" type="checkbox"/>	<input type="checkbox"/>	<input type="checkbox"/>	<input type="checkbox"/>	<input type="checkbox"/>	EN ISO 18854: 2015
Durability (Annex I B.3)	<input type="checkbox"/>	<input type="checkbox"/>	<input type="checkbox"/>	<input type="checkbox"/>	<input type="checkbox"/>	
Owner's manual (Annex I B.4)	<input type="checkbox"/>	<input type="checkbox"/>	<input type="checkbox"/>	<input type="checkbox"/>	<input type="checkbox"/>	
<b>Annex I.C – Noise Emissions</b>	See Declaration of Conformity of the recreational craft in which the engine(s) has (have) been installed					

<sup>1</sup> Such as non-harmonised standards, rules, regulations, guidelines, etc.

<sup>2</sup> Standards published in EU Official Journal

**This Page Intentionally Left Blank**

# YANMAR CO., LTD.

## ■ Large Power Products Management Division

### Quality Assurance Division

5-3-1, Tsukaguchi-honmachi, Amagasaki

Hyogo, 661-0001, Japan

Phone: +81-6-6428-3137 Fax: +81-6-6421-5549

<https://www.yanmar.com/>

## ■ Yanmar Marine International B.V.

Brugplein 11, 1332 BS Almere-de Vaart, Netherlands

Phone: +31-36-5493534 Fax: +31-36-5493219

<http://www.yanmarmarine.com/>

---

## Overseas Office

---

## ■ Yanmar Europe B.V. (YEU)

Brugplein 11, 1332 BS Almere-de Vaart, Netherlands

Phone: +31-36-5493200 Fax: +31-36-5493209

<http://www.yanmar.com/eu/>

## ■ Yanmar Asia (Singapore) Corporation Pte. Ltd. (YASC)

4 Tuas Lane, Singapore 638613

Phone: +65-6861-3855 Fax: +65-6862-5189

<https://www.yanmar.com/sg/>

## ■ Yanmar America Corporation (YA)

101 International Parkway,

Adairsville, GA 30103, U.S.A.

Phone: +1-770-877-9894 Fax: +1-770-877-9009

<http://www.yanmar.com/us/>

## ■ Yanmar Engine (Shanghai) Co., Ltd.

10F, E-Block Poly Plaza, No.18 Dongfang Road,

Pudong Shanghai, China P.R.C. 200120

Phone: +86-21-6880-5090 Fax: +86-21-6880-8090

<https://www.yanmar.com/cn/>

As of November 1st, 2017

## OPERATION MANUAL

1GM10, 1GM10C, 1GM10V

1st edition: November 2007

2nd edition 3rd rev.: February 2014

3rd edition: January 2017

4th edition: December 2017

4th edition 1st rev.: April 2018

Issued by: YANMAR CO., LTD. Large Power Products Management Division

Edited by: YANMAR TECHNICAL SERVICE CO., LTD.

***YANMAR***

**YANMAR CO., LTD.**

<https://www.yanmar.com>

0AGMM-EN0013  
30.4(YTSK)